

CONCORD INSTRUMENT  
DIVISION

MODEL 6053/3

FREQUENCY COUNTER

1875  
1876  
1877  
1878  
1879  
1880  
1881  
1882  
1883  
1884  
1885  
1886  
1887  
1888  
1889  
1890  
1891  
1892  
1893  
1894  
1895  
1896  
1897  
1898  
1899  
1900



# Concord Instrument Division

## INSTRUCTION MANUAL



CONCORD INSTRUMENT  
DIVISION  
MODEL 6053/3  
FREQUENCY COUNTER

© Copyright 1970 Systron-Donner Corporation

**SYSTRON**  **DONNER**  
CORPORATION

888 Galindo Street, Concord, California 94520, U.S.A.  
Tel: (415) 682-6161, TWX: 910-481-9478, Cable: SYSTRONDONNER



## WARRANTY

Systron-Donner instruments are warranted during a period of one year from date of shipment to original purchaser to be free from defects in material and workmanship. This warranty does not apply to vacuum tubes, except as they are warranted by tube manufacturers. The liability of Seller under this warranty is limited to replacing or repairing any instrument or component thereof which is returned by Buyer at his expense during such period and which has not been subjected to misuse, neglect, improper installations, repair, alteration, or accident. Seller shall have the right of final determination as to the existence and cause of a defect. In no event shall Seller be liable for collateral or consequential damages. This warranty is in lieu of any other warranty, express, implied or statutory, and no agreement extending or modifying it will be binding upon Seller unless in writing and signed by a duly authorized officer.

## RECEIVING INSPECTION

Every Systron Donner instrument is carefully inspected and is in perfect working order at the time of shipment. Each instrument should be checked as soon as received. If the unit is damaged in any way or fails to operate, a claim should immediately be filed with the transportation company.

## REPAIRS

Whenever a Systron-Donner instrument requires service, the nearest Systron-Donner representative should be contacted; all representatives will provide immediate service or arrange factory returns when necessary.

Please specify both model and serial number in all correspondence concerning Systron-Donner instruments. Address all inquiries on operation or applications to your nearest sales representative or Sales Manager, Instruments, Systron-Donner Corporation, 888 Galindo Street, Concord,

LIST OF EFFECTIVE PAGES  
 Original Dated: 11-70

Page Numbers	Change In Effect	Page Numbers	Change In Effect
i - vii	Original	4-1 - 4-13	Original
1-1 - 1-4	Original	5-1 - 5-4	Original
2-1 - 2-2	Original	6-1 - 6-40	Original
3-1 - 3-6	Original		

Errors found in this publication (other than obvious typographical errors), which have not been corrected by means of Temporary Corrections or Permanent Changes should be reported. Such report should include the complete title of the publication and publication number (short title); identify the page and line or figure and location of the error; and be forwarded to the Technical Publications Department, Concord Instrument Division, 888 Galindo St., Concord, California 94520.



# TABLE OF CONTENTS

		Page
CHAPTER 1 - GENERAL INFORMATION		
1.1	Introduction . . . . .	1-1
1.2	Functional Description . . . . .	1-1
1.3	Specifications . . . . .	1-1
CHAPTER 2 - INSTALLATION		
2.1	Introduction . . . . .	2-1
2.2	Receiving Inspection . . . . .	2-1
2.3	Installation . . . . .	2-1
2.3.1	Power . . . . .	2-1
2.3.2	Cooling . . . . .	2-2
2.4	Reshipment . . . . .	2-2
CHAPTER 3 - OPERATION		
3.1	Introduction . . . . .	3-1
3.2	Controls, Connectors, and Indicators . . . . .	3-1
3.3	Initial Turn-On and Operational Check . . . . .	3-4
3.4	Operating Procedures . . . . .	3-5
3.4.1	General . . . . .	3-5
3.4.2	20Hz - .2GHz Range . . . . .	3-5
3.4.3	.2 - 3GHz Range . . . . .	3-5
3.4.4	Turn-Off Procedures . . . . .	3-6
CHAPTER 4 - THEORY OF OPERATION		
4.1	Introduction . . . . .	4-1
4.2	General Theory . . . . .	4-1
4.3	Circuit Descriptions . . . . .	4-1
4.3.1	Power Supply (Schematic C39082) . . . . .	4-1
4.3.2	A2, Shield Board (Schematic D39100) . . . . .	4-5
4.3.3	A3, Counter Readout Assembly (Schematic D33997) . . . . .	4-5
4.3.4	200MHz Amp and Decade (Schematic D39095) . . . . .	4-10
4.3.5	A5, Acto (Schematic C39087) . . . . .	4-11
4.3.6	A6, Acto Mixer/Driver (Schematic C27988) . . . . .	4-12
CHAPTER 5 - CALIBRATION-MAINTENANCE		
5.1	Introduction . . . . .	5-1
5.2	Factory Service . . . . .	5-1
5.3	Part Location . . . . .	5-1
5.4	Calibration Procedure . . . . .	5-1
5.4.1	Power Supply Adjustments (Schematic C39082) . . . . .	5-1

# TABLE OF CONTENTS (Cont'd)

		Page
CHAPTER 5 - CALIBRATION-MAINTENANCE (Cont'd)		
5.4.2	Oscillator Adjustment . . . . .	5-2
5.4.3	200 MHz Input Amp and Decade Adjustments (Schematic D39095) . . . . .	5-2
5.4.4	Acto Adjustment (Schematic C39087) . . . . .	5-3
5.5	Board Repair . . . . .	5-3
CHAPTER 6 - DRAWINGS AND PARTS LIST		
D39100R3	Interconnect Diagram . . . . .	6-2
	Parts List . . . . .	6-3
C39082R2	A1, Power Supply Assembly D39085R2 . . . . .	6-4
	A1, Power Supply Schematic D39082R2 . . . . .	6-5
	Parts List . . . . .	6-6
C39448R2	A2, Shield Board Assembly C39448R2 . . . . .	6-8
	Parts List . . . . .	6-9
D33997R4	A3, Readout P.C. Assembly D39000R2 . . . . .	6-10
	A3, Readout Schematic (Sh. 1) D33997R4 . . . . .	6-11
	A3, Readout Schematic (Sh. 2) D33997R4 . . . . .	6-12
	Parts List . . . . .	6-13
D39095R4	A4, 200MHz Amp & Decade Assembly D39098R5 . . . . .	6-20
	A4, 200MHz Amp & Decade Schematic D39095R4 . . . . .	6-21
	Parts List . . . . .	6-22
C39087R2	A5, Acto P.C. Assembly C39090R2 . . . . .	6-28
	A5, Acto Schematic C39087R2 . . . . .	6-29
	Parts List . . . . .	6-30
C27988C	A6, Mixer P.C. Assembly C33218C . . . . .	6-34
	A6, Mixer & Driver Amp Schematic C27988C . . . . .	6-35
	A6, Mixer Final Assembly C33351B . . . . .	6-36
	Parts List . . . . .	6-37
	A6, Driver Amp P.C. Assembly C33221C . . . . .	6-39
	Parts List . . . . .	6-40
CHAPTER 7 - STANDARD OPTIONS		
B39490R1	U1, 3MHz Oscillator Assembly B39487R1 . . . . .	7-2
	U1, 3MHz Oscillator Schematic B39490R1 . . . . .	7-3
	Parts List . . . . .	7-4
C39113R2	BCD Board Assembly A39119R1 . . . . .	7-6
	BCD Board Schematic C39113R2 . . . . .	7-7
	Parts List . . . . .	7-8



## LIST OF FIGURES

		Page
Figure 2.1	Transformer Jumper Position for Power Change . . . . .	2-2
3.1	Front Panel, Model 6053/3 . . . . .	3-2
3.2	Rear Panel, Model 6053/3 . . . . .	3-2
4.1	Model 6053/3 Block Diagram . . . . .	4-3
4.2	Timing Diagram, Model 6053/3 . . . . .	4-4
5.1	Voltage Measurement of RF Input . . . . .	5-3

## LIST OF TABLES

Table 1.1	Specifications . . . . .	1-1
3.1	Front Panel . . . . .	3-1
3.2	Rear Panel . . . . .	3-3
3.3	Check, In Test . . . . .	3-5
4.1	Logic States . . . . .	4-6
4.2	Function BCD . . . . .	4-7
5.1	Power Supply Adjustment . . . . .	5-2



CHAPTER 1  
GENERAL INFORMATION

### 1.1 INTRODUCTION

The SD Model 6053/3 is a portable, half-rack, microwave counter capable of automatically measuring signal frequencies ranging from 20Hz to 3GHz. Extensive use of integrated circuits and other solid-state components ensures excellent reliability and trouble-free maintenance.

The Model 6053/3 microwave counter provides the following operating features:

1. An easily read storage-type display which permits the initial reading to be observed while another is being made.
2. Direct reading of frequency with no front panel adjustment necessary.
3. Automatic units of measure and decimal point location.
4. Completely remote programmable: programming inputs for all front panel controls and attenuator switch (optional).
5. BCD recorder output (optional).
6. Unit can be operated on either 115V or 230V ac line.

### 1.2 FUNCTIONAL DESCRIPTION

The Model 6053/3 features the Automatic Computing Transfer Oscillator (ACTO<sup>R</sup>) technique in conjunction with a new high-sensitivity, high input impedance .2GHz amplifier to offer unparalleled performance. The basic seven-digit instrument receives its input on one of two input connectors.

1. BNC - This 20Hz to .2GHz input channel features 10mV rms sensitivity and one megohm impedance. Input signals may be attenuated by factors from 1 to 1000, in decade steps.
2. "N" type connector - Frequencies from .2GHz to 3GHz can be measured with sensitivities of 50mV rms into 50 ohms.

### 1.3 SPECIFICATIONS

Table 1.1 lists the specifications applicable to the Model 6053/3:

TABLE 1.1 SPECIFICATIONS

Low-Frequency Range Input	Frequency Range:	20Hz to .2GHz.
	Type of Signal:	CW.
	Sensitivity:	10mV rms.

TABLE 1.1 SPECIFICATIONS (Cont'd)

	Maximum Input Without Damage:	600V dc, 200V rms.
	Input Impedance:	1M $\Omega$ .
	Input Connector:	Type BNC.
	Accuracy:	$\pm 1$ count $\pm$ time base accuracy.
	Resolution:	100kHz to 0.1Hz in decade steps.
	Reads In:	MHz or GHz.
High-Frequency Range Input	Frequency Range:	.2GHz to 3GHz.
	Type of Signal:	CW.
	Sensitivity:	50mV rms (-7 dBm).
	Maximum Input Without Damage:	2.33V rms (+20 dBm).
	Maximum Usable Input:	500mV rms (+7 dBm).
	Input Impedance:	50 $\Omega$ nominal.
	Input Connector:	Type N.
	Accuracy:	$\pm 1$ count $\pm$ time base accuracy.
	Resolution:	100kHz to 0.1Hz in decade steps.
	Reads In:	MHz or GHz.
	Acquisition Time:	200ms typical.
	FM Tolerance:	Maximum of 0.1% deviation at modulation frequency of 60Hz. Permissible deviation is reduced 50% for each increasing octave of modulation frequency.
	Maximum Amplitude Modulation:	70% (400Hz to 1kHz).

TABLE 1.1 SPECIFICATIONS (Cont'd)

	Lock-On Range:	Approximately 5% of input frequency.
Time Base	Crystal Frequency:	1MHz.
	Stability:	$\pm 2$ parts in $10^6$ /month.
	Temperature:	Less than $\pm 1$ part in $10^5$ from $+15^\circ\text{C}$ to $+35^\circ\text{C}$ ; less than $\pm 3$ parts in $10^5$ from $0^\circ\text{C}$ to $+50^\circ\text{C}$ .
	Line Voltage:	Less than $\pm 1$ part in $10^6$ for 10% change in line voltage specified.
	Output Frequency:	1MHz, 3V p-p minimum open circuit; source impedance $2000\Omega$ maximum.
	External Input:	1MHz sinewave, 1V rms into $1000\Omega$ , 10V rms maximum.
	Higher Stability Available:	See options listed.
General	Registration:	7 digits, expandable to 9.
	Reads In:	MHz or GHz with positioned decimal point.
	Display Storage:	Provides a continuous display of most recent measurement.
	Rear Panel:	1MHz internal/external switch, BNC connector for 1MHz input or output, line cord, oscillator adjustment, fuse.
	Operating Temperature:	$0^\circ\text{C}$ to $+50^\circ\text{C}$ .
	Dimensions:	3-1/2" high x 8-3/8" wide x 13" deep.
	Weight:	10 lbs. net (15 lbs. shipping).
	Power:	115V/230Vac, 50 to 60Hz.

TABLE 1.1 SPECIFICATIONS (Cont'd)

Options	B3	Aging Rate: $<\pm 3$ parts in $10^8/24$ hours. Long-Term Aging Rate: $\pm 3$ parts in $10^8/30$ days. Short-Term Aging Rate: $\pm 1$ part in $10^{10}$ rms/ls average.
	B	Aging Rate: $<\pm 1$ part in $10^9/24$ hours. Long-Term Aging Rate: $\pm 3$ parts in $10^8/30$ days. Short-Term Aging Rate: $\pm 1$ part in $10^{10}$ rms/ls average.
	B4	Aging Rate: $<\pm 5$ parts in $10^{10}/24$ hours. Long-Term Aging Rate: $\pm 1.5$ parts in $10^8/30$ days. Short-Term Aging Rate: $\pm 5$ parts in $10^{11}/1s$ average.
	E & EE	Additional decade indicator to increase count capacity to 8 (E) or 9 (EE) digits.
	D3	1-2-4-8 BCD Output: Coded output information of front panel reading appears at rear panel connector. Positive logic "1" state level at +5V nominal, "0" state level at $0V \pm 0.5V$ ; a +5V print command at the end of each conversion, positive reference level is +4V, negative reference level is +1V with a column capacity equal to the number of digits.
	P	Remote programming of range, resolution and attenuators. T <sup>2</sup> L, DTL compatible.

## CHAPTER 2 INSTALLATION

### 2.1 INTRODUCTION

Procedures for inspection and initial installation of SD Model 6053/3 are outlined below. Reshipment instructions have been included should the instrument require return to Systron-Donner Corporation.

### 2.2 RECEIVING INSPECTION

Before accepting the instrument from the shipper, inspect the shipping container for signs of external damage. Any sign of such damage must be noted by both the shipper and customer; then, should be reported to the insurance investigator.

As soon as the instrument is unpacked, inspect it for shipping damage. Check for scratches or dents, broken or cracked knobs, and damaged connectors. Should any damage be found, notify your nearest Systron-Donner representative -- do not use the instrument until instructed to do so by the representative.

### 2.3 INSTALLATION

Initial installation of the Model 6053/3 includes power connection and verification of internal cooling.

#### 2.3.1 Power

The Model 6053/3 may be operated from a 115 or 230-volt ac ( $\pm 10\%$ ) power source. Conversion from one source to another is performed by changing jumpers on the power transformer (See Figure 2.1).

The instrument is factory-supplied with a 1A, 3AG fuse for 115V operation. Be sure to replace this fuse with a .5A, 3AG fuse when operating with 230V.

#### CAUTION

*Before connecting instrument into ac power line, be certain that transformer is wired for proper power.*

The Model 6053/3 is equipped with a standard three-conductor power cord that automatically grounds the unit when a matching power outlet is available. An adapter which provides the instrument ground should be used whenever the power cord is connected to a two-conductor outlet.

### 2.3.2 Cooling

The Model 6053/3 Counter uses forced air cooling. The air intake is located on the rear panel of the instrument. Make sure the air intake filter is clean and in place before applying power to the instrument. Under no circumstances should the air intake be obstructed while the instrument is operating.

### 2.4 RESHIPMENT

Should it become necessary to reship the instrument, contact the nearest Systron-Donner field office for shipping instructions. If possible, use the original packaging materials, or replace the packing in accordance with MIL-P-116 and MIL-E-17555E. The field office can provide materials similar to those used for original factory packaging. All correspondence should refer to the full nomenclature and serial number of the instrument.

#### BOTTOM VIEW OF INSTRUMENT

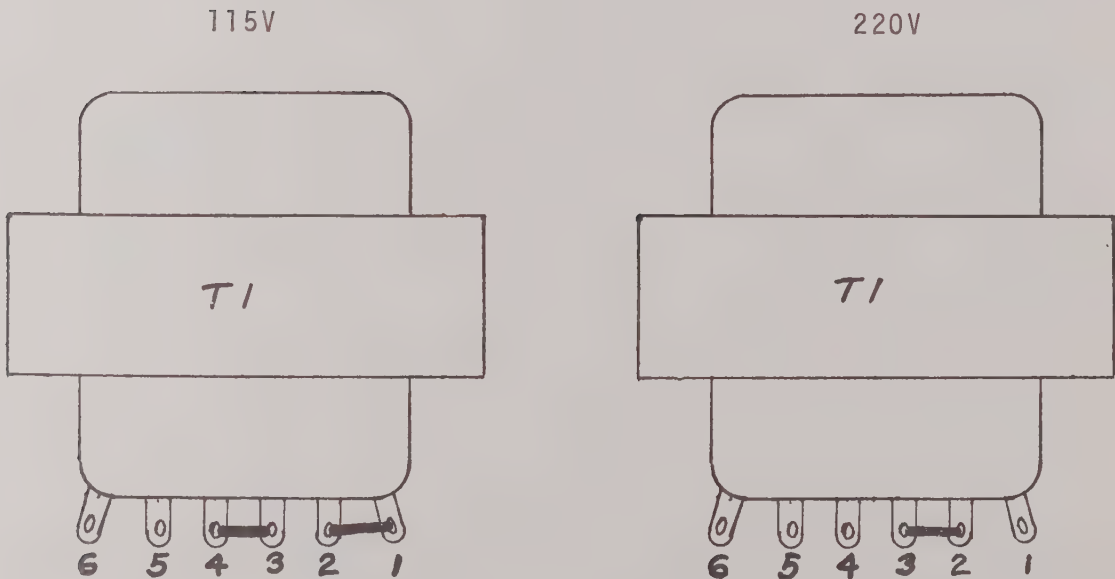

FIGURE 2.1 TRANSFORMER JUMPER POSITION FOR POWER CHANGE



CHAPTER 3  
OPERATION

3.1 INTRODUCTION

This section describes the SD Model 6053/3 controls, connectors, and indicators. Initial turn-on and operational checks are included, along with step-by-step operating procedures listing each basic function of the counter.

3.2 CONTROLS, CONNECTORS, AND INDICATORS

Figures 3.1 and 3.2 illustrate the Model 6053/3 front and rear panel controls, connectors, and indicators. Table 3.1 and 3.2 provide a description of these functions.

TABLE 3.1 FRONT PANEL

FIGURE INDEX	NAME	FUNCTIONS
3.1 1	POWER (pushbutton)	Applies power to the instrument.
3.1 2	TEST (pushbutton)	Applies the 1MHz internal oscillator frequency to the internal circuits for test.
3.1 3	RANGE .2 - 3GHz (pushbutton)	Activates "N" connector (see Index 11) for input of .2-3GHz.
3.1 4	RANGE 20Hz - .2GHz ATTENUATOR (pushbuttons)	X1 X10 X100 X1k Attenuates the input applied to the 1M $\Omega$ , 20Hz - .2GHz BNC connector by a factor of 1 (X1), 10 (X10), 100 (X100), and 1000 (X1k).
3.1 5	DISPLAY (indicator)	Digital indicators and polarized window provide glare-free viewing of measurement.
3.1 6	20Hz - .2GHz 1M $\Omega$ (connector)	Type BNC provides signal input connection for the 20Hz - .2GHz range of measurement.

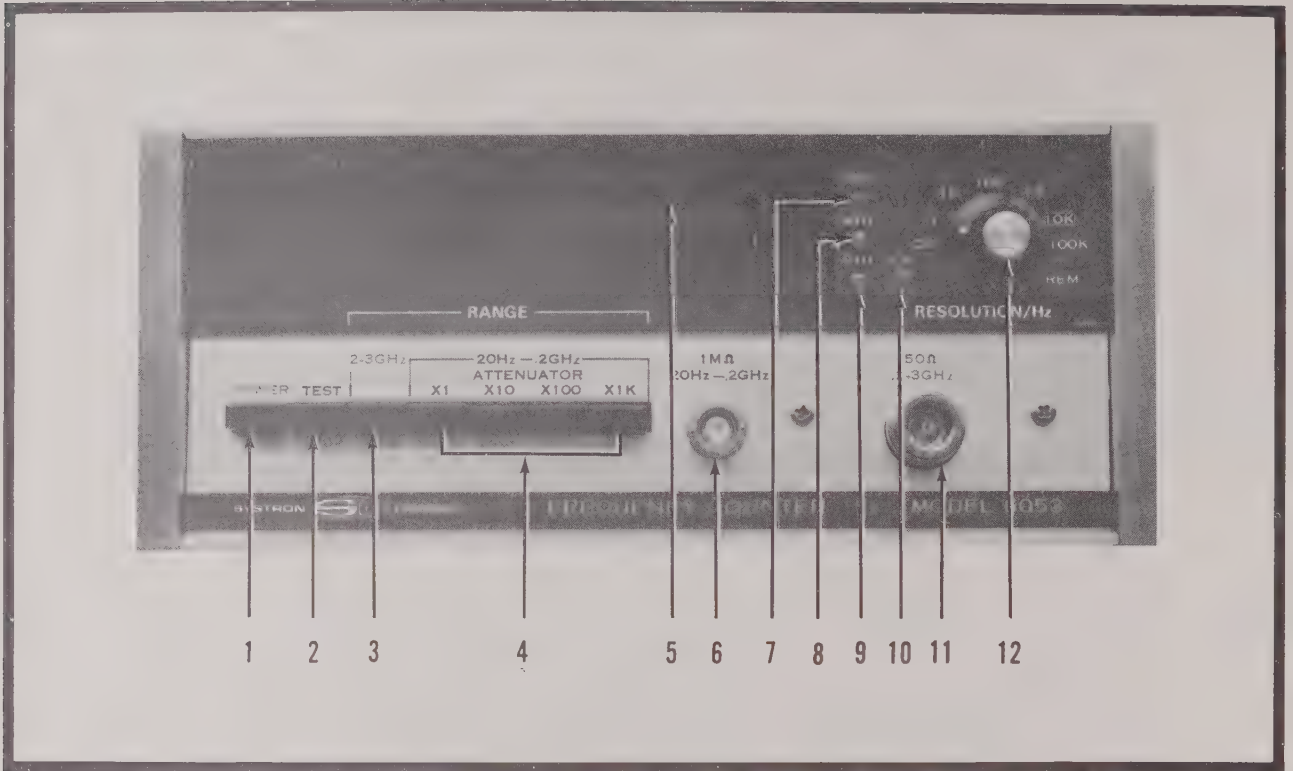

FIGURE 3.1 FRONT PANEL, MODEL 6053/3

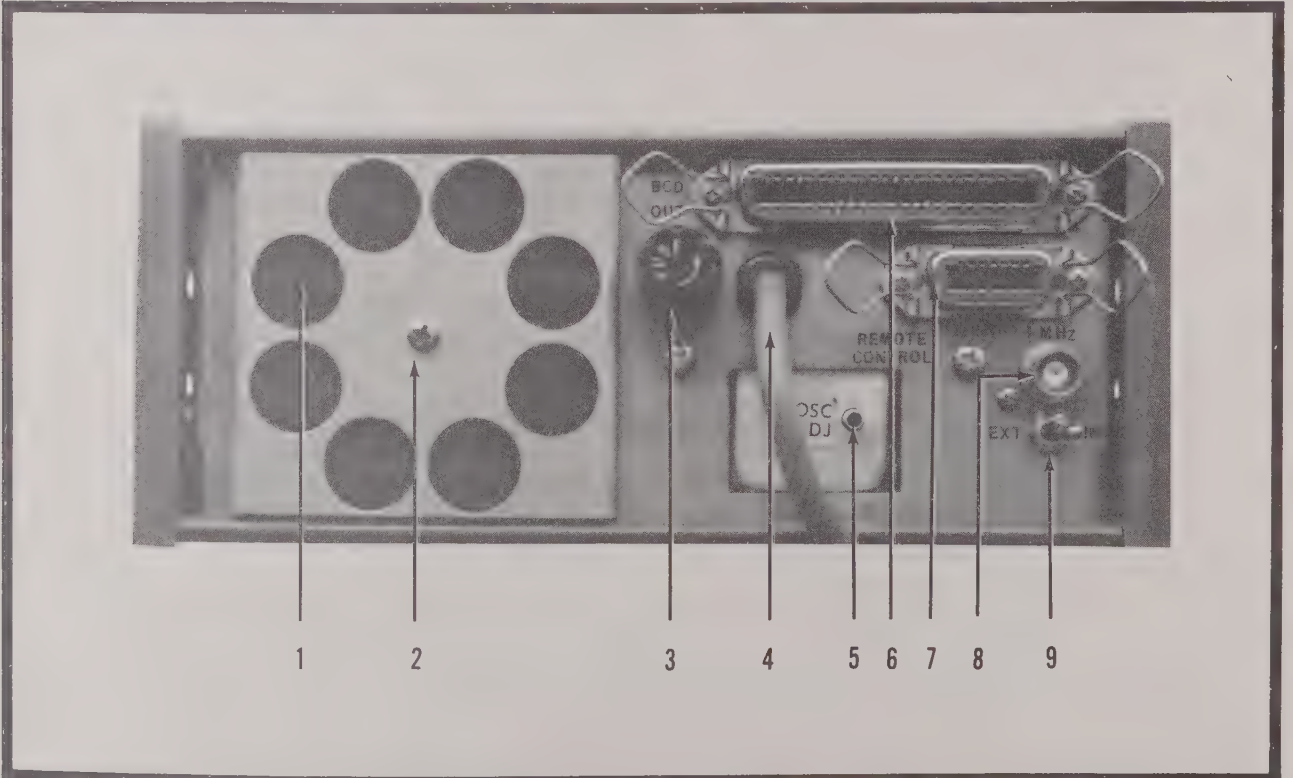

FIGURE 3.2 REAR PANEL, MODEL 6053/3

TABLE 3.1 FRONT PANEL (Cont'd)

FIGURE INDEX	NAME	FUNCTIONS	
3.1 7	GATE (indicator)	Light-emitting diode (LED) indicates when the count gate is open or closed.	
3.1 8	MHz (indicator)	Light-emitting diode (LED) when energized, indicates that readout units are in MHz.	
3.1 9	GHz (indicator)	Light-emitting diode (LED) when energized, indicates that readout units are in GHz.	
3.1 10	O.S. (indicator)	Light-emitting diode (LED) when energized, indicates that a reading is off-scale.	
3.1 11	.2 - 3GHz 50Ω (connector)	Type N connector provides signal input connection for .2 - 3GHz.	
3.1 12	RESOLUTION/Hz (switch)	$10^{-1}$ , 1, $10^1$ , $10^2$ , $10^3$ , $10^4$ , $10^5$ , REM.	Switch provides 7 ranges of resolution and a remote position for programmable operation.

TABLE 3.2 REAR PANEL

FIGURE INDEX	NAME	FUNCTION
3.2 1	FAN INTAKE	Air intake for cooling.
3.2 2	FAN SCREEN	Screens dust and particulate matter from cooling air (should be cleaned weekly).
3.2 3	FUSE HOLDER	Retains power fuse.
3.2 4	POWER CORD	3-conductor grounded power cord.

TABLE 3.2 REAR PANEL (Cont'd)

FIGURE	INDEX	NAME		FUNCTION
3.2	5	1MHz OSCILLATOR (controls)	Coarse Fine	Adjusts the internal 1MHz oscillator frequency.
3.2	6	BCD OUT (optional connector)		Provides BCD information compatible with IC logic.
3.2	7	REMOTE CONTROL (optional connector)		Permits remote operation of attenuator and all front panel controls.
3.2	8	1MHz (connector)		Provides 1MHz out when INT/EXT switch is in INT position. Provides input for external 1MHz signal when INT/EXT switch is in EXT position.
3.2	9	INT/EXT (switch)		Provides selection of internal or external time base.

### 3.3 INITIAL TURN-ON AND OPERATIONAL CHECK

The following procedures verify operation of the Model 6053/3 prior to on-line usage. Successful completion of these checks should precede any performance tests.

1. Connect power cord to 115V ac source.

*CAUTION*

*Be sure transformer is wired for 115V operation (see Section 2.3.1).*

2. Position INT/EXT switch (Index 9, Figure 3.2) to INT.
3. Press POWER pushbutton to ON (Index 1, Figure 3.1).
4. Press TEST pushbutton to ON (Index 2, Figure 3.1).
5. Check instrument readout (Table 3.3) while turning RESOLUTION/Hz switch through the (7) selectable ranges.

TABLE 3.3 CHECK, IN TEST

RESOLUTION/Hz SWITCH POSITION	READOUT INDICATION
$10^{-1}$	XX.0000000 MHz (O.S.)
1	XX1.000000 MHz
10	XX01.00000 MHz
$10^2$	XX001.0000 MHz
$10^3$	XX0.001000 GHz
$10^4$	XX00.00100 GHz
$10^5$	XX000.0010 GHz
REMOTE	Same as above

XX - Additional digits available, E and EE Options

### 3.4 OPERATING PROCEDURES

The following procedures outline the general method for operating the Model 6053/3 in the two measurement ranges.

#### 3.4.1 General

Operation is fully automatic and requires no special adjustments.

#### 3.4.2 20Hz - .2GHz RANGE

- 1) Press POWER pushbutton to ON.
- 2) Press proper attenuator pushbutton in accordance with input level. If input level is unknown, select highest attenuation level (X1k) first; then, proceed to select lower attenuation levels (X100, X10, or X1) to obtain consistent count readings.
- 3) Apply 20Hz - .2GHz signal to 1M $\Omega$  Type BNC connector.
- 4) Select desired readout resolution.
- 5) Measurement is automatic.

#### 3.4.3 2 - 3GHz RANGE

- 1) Press POWER pushbutton to ON.
- 2) Press .2 - 3GHz pushbutton

- 3) Apply .2 - 3GHz signal to 50 $\Omega$  Type N connector.
- 4) Select desired readout resolution.
- 5) Measurement is automatic.

#### 3.4.4 Turn-off Procedures

- 1) Press POWER pushbutton to OFF.
- 2) Disconnect power cord from ac source.

#### NOTE

*Do not disconnect power cord from ac source if B, B3, or B4 Oscillator Option is installed.*

*(Crystal oven must remain energized at all times to ensure high-accuracy readout operation.)*

## CHAPTER 4

### THEORY OF OPERATION

#### 4.1 INTRODUCTION

Included in this chapter are the general theory and circuit descriptions of the Model 6053 Counter. A general block diagram, along with a timing diagram, are included for reference. Schematics will be found in Chapter 6.

#### 4.2 GENERAL THEORY

The Automatic Computing Transfer Oscillator (ACTO) operates by phase-locking a low frequency oscillator to the applied RF input frequency and computing the harmonic multiple "N". The counter time base is then expanded such that the counter will count the low frequency oscillator for a period equal to "N" times the selected time base. The result is a direct indication of the RF input frequency. Figure 4.1 depicts the basic block diagram for the ACTO. As illustrated, the phase-lock loop incorporates a harmonic phase detector, amplifier search oscillator, and a voltage-controlled oscillator. The free-running search oscillator sweeps the voltage-controlled oscillator over a narrow band of frequencies, producing an output varying in frequency between 17.5 and 19.5MHz. This signal is applied to the harmonic phase detector and is phase-compared to the RF input. When an exact oscillator harmonic is encountered, a dc voltage is generated which disables the sweep oscillator and locks the voltage-controlled oscillator to a sub-multiple of the input frequency.

Since the harmonic number (N) is unknown, it is not possible to measure the exact input frequency. Therefore, a second output from the voltage-controlled oscillator is extracted and applied to a single-sideband generator. The generator is modulated at a 1kHz rate resulting in an output equal to the oscillator's frequency shifted by 1kHz. This signal is now applied to a harmonic phase detector, the output of which is equal to  $1\text{kHz} \times N$ .

Since the original 1kHz modulation frequency and the  $1\text{kHz} \times N$  are present, it is possible to compare the two frequencies digitally and extract the corresponding harmonic number (N). This is the function of the N compute and control circuit. Having extracted N, the N compute and control circuit expands the time base period by the appropriate factor of N to provide a direct readout of the input frequency.

#### 4.3 CIRCUIT DESCRIPTIONS

##### 4.3.1 POWER SUPPLY (Schematic C39082)

The Model 6053 power supply provides both regulated and unregulated voltages from either a 115V or 230V, 50 to 60Hz source.

Primary power arrives at the primary windings of power transformer T1 from the ac line cord, through a line filter, fuse F1, and a POWER/ON switch S1. The power transformer provides three separate secondary windings from which the following voltages are obtained: +225V dc (indicator tubes), +5V dc (logic), and ±15V dc (bias). A special ACTO +5V dc and -5.2V dc are provided with additional circuitry.

#### +225 Supply (unregulated)

The +225V supply voltage is produced in the following manner: approximately 175V rms from the T1 secondary winding, 5-6 is half-wave rectified by CR5. The resultant voltage is distributed to the indicator tube circuitry on the Readout Board via pin E30.

#### +15V Supply (regulated)

The regulated +15V supply is based on 35V rms from the center-tapped secondary winding, 10-11-12. A full-wave bridge rectifier, CR1-CR4, and filter capacitor C2 produce a +22 volt dc potential which is applied to the integrated circuit regulator, U1. The regulated +15V output is then controlled by the series pass transistor Q1, permitting about 300mA maximum current at pins E19-E21.

#### -15V Supply (regulated)

The regulated -15V supply is based on 35V rms from the center-tapped secondary winding, 10-11-12, and referenced to the +15V regulated supply. The -22 volt dc potential, filtered by C3, is fed through R8 and pass transistor Q4 to the differential amplifier Q2 and Q3. This amplifier keeps the junction of R7 and R9 at 0 potential.

Since R7 and R9 are equal, the voltage drop across each is the same. Thus, if R2 adjusts the +15V supply, the -15 volts across R9 will track. 300mA is available at pins E26-E28.

#### +5V Supply (regulated)

From secondary winding 7-8-9 of T1 and the full-wave bridge, CR6-CR9, a +9V potential is fed to IC regulator U2. The resulting regulated +5V is then passed by Q9, providing about 1.35A of current at E24-E25.

#### -5.2V Supply (regulated)

From secondary winding 7-8-9 of T1 and the full-wave bridge, a -9V potential is fed to buffer amplifier Q7 and Q8; then, the differential amplifier Q5 and Q6 which references the resulting -5.2V with the regulated +5V supply.

#### ACTO +5 (regulated)

This supply is referenced to the +15 volt supply by the differential pair contained in U3 and adjusted by R17. The pass transistor Q11 allows 2.0A maximum at E22-E23. E29 is the ACTO enable line which enables Q10 when the ACTO line is grounded, turning on U3.



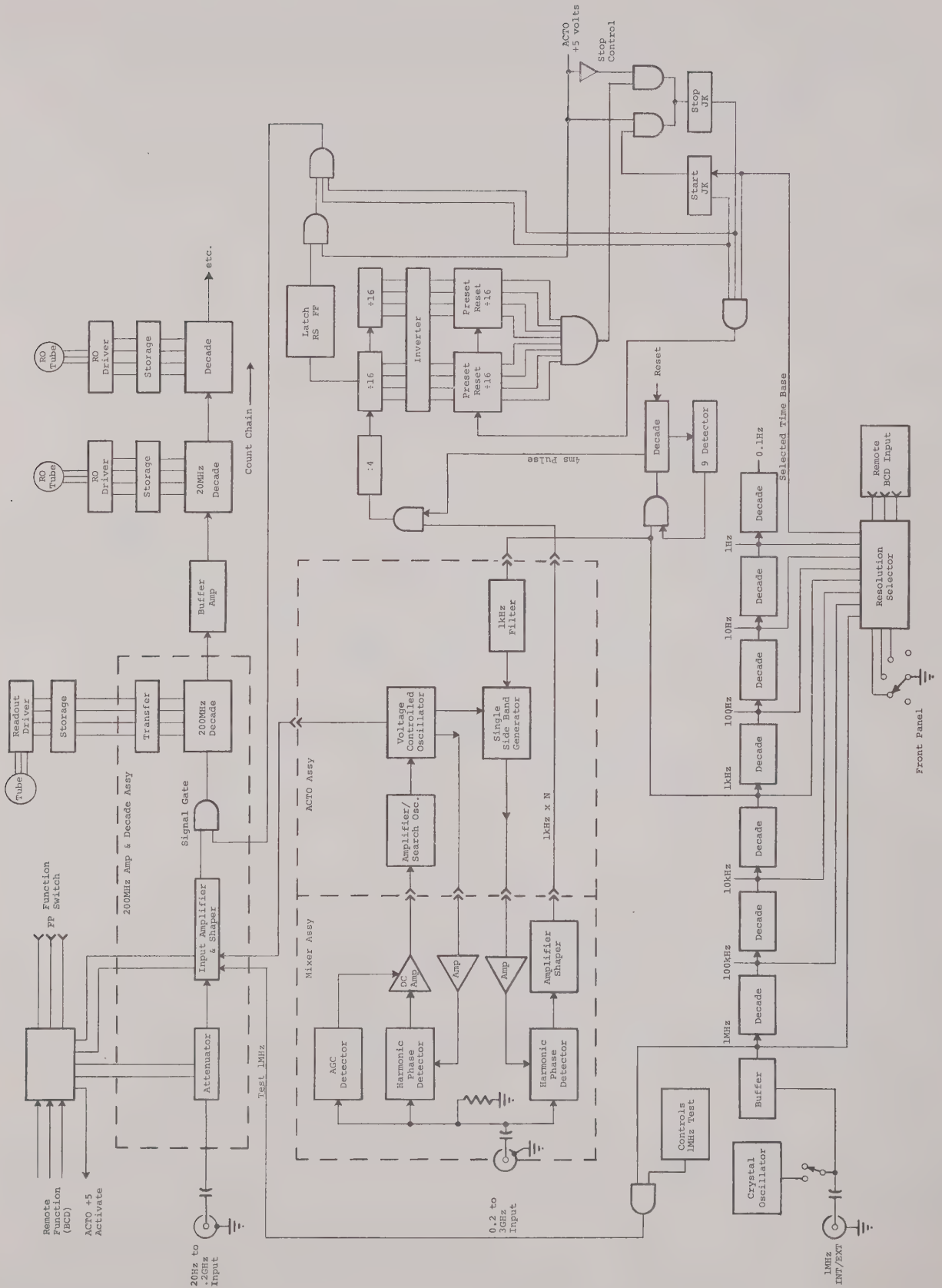

FIGURE 4.1 MODEL 6053/3 BLOCK DIAGRAM

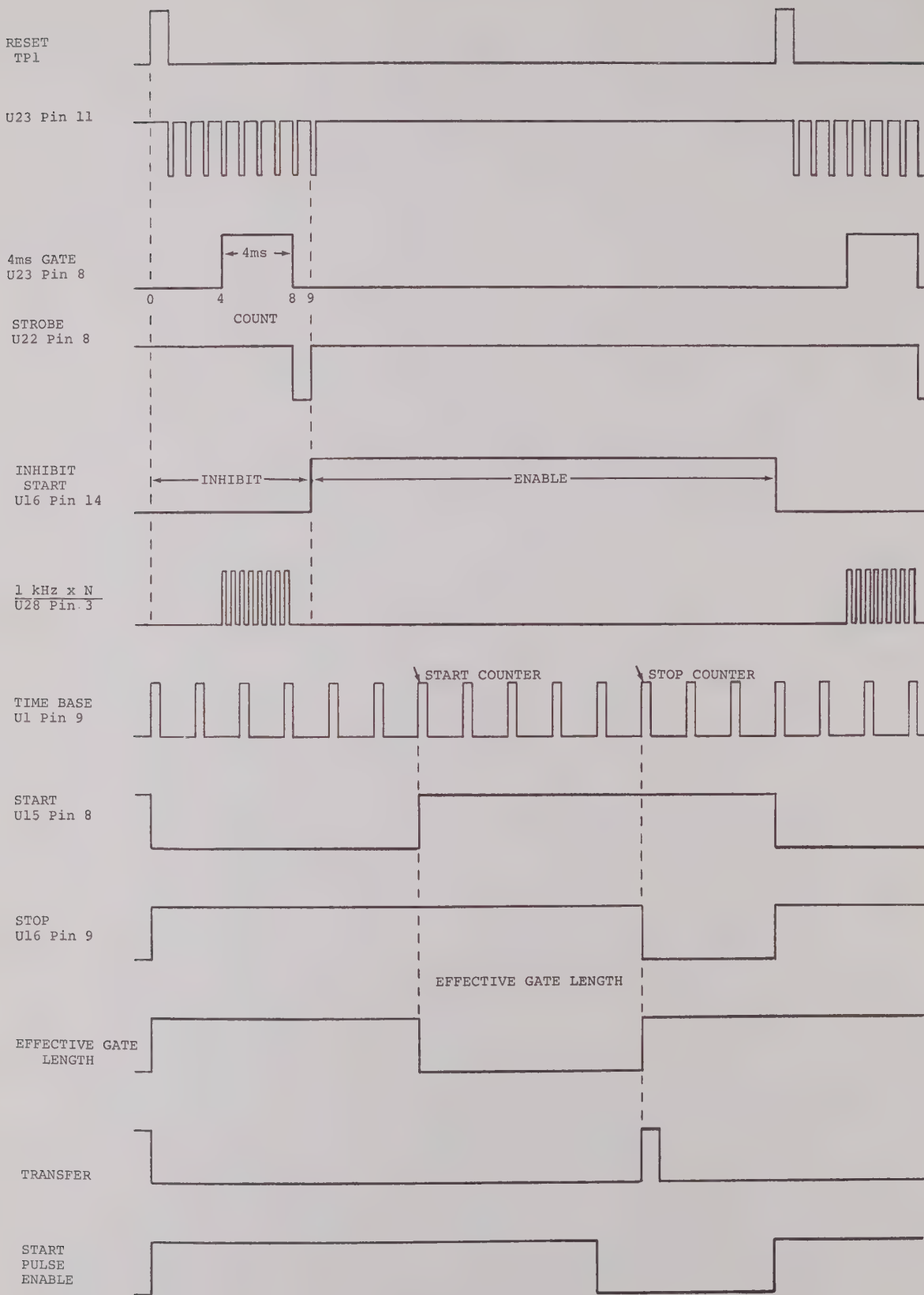

FIGURE 4.2 TIMING DIAGRAM, MODEL 6053/3

#### 4.3.2 A2, SHIELD BOARD (Schematic D39100)

This circuit selects the various functions by pushbuttons located on the front panel. Refer to the Interconnect Diagram in Chapter 6.

#### 4.3.3 A3, COUNTER READOUT ASSEMBLY (Schematic D33997, Pages 1 & 2)

Included on this assembly are:

1. The time base count chain.
2. The resolution and function logic, both for internal and external BCD control.
3. The signal gate control circuitry.
4. The Count Chain.
5. The ACTO "N" computer circuitry.

##### 1. Time Base Count Chain

The internal 1MHz time base is applied to the count chain at terminal E42. This time base is derived from either an internal 6053 crystal-controlled oscillator or from an external standard.

It is first shaped by the Schmitt trigger Q1 and Q2; then, translated to TTL logic levels by Q3. It then drives U2 pin 14, the first decade in the counting chain. It is followed by U3, U4, U5, U6, U7, and U8, the remainder of the time base decades.

##### 2. Resolution And Function Logic

The outputs of the time base dividers become seven inputs of the two data selectors U1 and U9. Pins 9, 10, and 11 of these data selectors control, by BCD logic, which of the seven input time base frequencies will appear at U1 pin 5 as the selected time base frequency.

U1 normally selects the time base frequency and is BCD controlled by the 6053 front panel resolution switch. When this switch is turned to the remote position, however, it selects the eighth input, U1 pin 1 which is connected to the output of U9. U9, in turn, is controlled externally through its BCD inputs which connect to the remote control connector.

The following logic levels appear at the specified pins of the resolution switch giving both internal and remote switch positions.

TABLE 4.1 LOGIC STATES

Internal Pins	E4	E8	E9		
Remote Pins	E37	E39	E41	Decimal Point Position	Binary Number
Remote	0	1	1	-	3
100 kHz	0 ] GHz	0	0	4	0
10 kHz		0	1	5	1
1 kHz		0	1	0	6
100 Hz	1 ] MHz	0	0	4	4
10 Hz		0	1	5	5
1 Hz		1	0	6	6
0.1 Hz		1	1	1	7

The logic level at J5 if it is in the 1 state, drives U14 pins 1, 2 and 4 to the 1 state. Pin 3 of U15 goes to 0 and pin 6 of U15 goes to a 1 state. Pin 6 of U14 then goes to a 0 state turning Q6 off, extinguishing the GHz lamp and turning Q7 on; thus, supplying current to the MHz lamp.

A 0 at J5 has the opposite effect. By the presence of a 0 at U14 pin 4, U14 pin 6 is driven to a 1 state turning Q6 on, supplying current to the GHz lamp, turning Q7 off, extinguishing the MHz lamp.

Decimal Point

There are three decimal points in the GHz range and four decimal points in the MHz range. As seen from the chart they are positions 4, 5, 6, and 7. They are, with the exception of number 7, the same in the MHz range and in the GHz range. The decimal points are located in the display tubes and are switched by U29, a 4 to 10-line converter. The logic levels at the inputs of U29 are:

Tube	A	B	C	D
4	0	0	1	0
5	1	0	1	0
6	0	0	1	0
7	1	1	1	0

Since the logic levels in the C and D columns do not change they are permanently wired to the 1 and 0 logic levels. The logic levels at A and B are obtained from the terminal lugs, J3, J4 and are inverted by the two gate functions of U10, driving the 4 to 10-line converter U29 which lights the correct decimal point.

When the resolution switch is in the remote position, the decimal point logic is supplied to the external rear panel connector J5 through the other two gating elements of U10.

### Function Switch

The front panel function switch is a set of six pushbuttons which supply BCD information to three sections of the quad gate U11. When the resolution switch is in "Remote", the 6053 functions are controlled by BCD from rear panel connector J5, operating the three sections of the Quad gate U12. The functions and BCD information required at lugs E31, E38, and E36; E33, E28, and E29 respectively are as follows:

TABLE 4.2 FUNCTION BCD

Remote	E33	E28	E29
Front Panel Control	E31	E38	E36
Test	1	0	0
Hi Frequency	0	0	0
X1	1	1	1
X10	0	1	1
X100	1	0	1
X1k	0	0	1

### 3. Signal Gate Control

The unijunction transistor Q13 fires developing a positive pulse at base 1. This is amplified and inverted by Q14 and turns Q15 off for the duration of the pulse. The positive pulse at the collector of Q15 resets all the counting decades, the 1Hz and 0.1Hz time base decades, as well as U26, U27, and U23. The positive pulse is inverted by U25 and then resets U16, U30; it is also available at pin E24.

U23, a decade counter, is normally driven by 1kHz from U4, a time base divider, through the gate function U17. It will count the 1kHz until the decade reaches the count of nine, at which time it drives the two input pins 4 and 5 of U22 to the 1 state. Pin 6 of U22 then becomes a 0 and disables U17, preventing any more 1kHz pulses from reaching the input of U23. Pin 6 of U22 is inverted by U18. Pin 8 of U18 then becomes an inhibit-start signal for the stop flip-flop U16 by holding the J line, pin 14, of U16

down in the 0 state. Pin 12 had been set to the 1 state by the negative reset pulse at pin 6 and pin 2.

The dual JK flip-flop U16 is initially reset with pin 12 and pin 9 in the logical 0 state. (Low voltage state.) The voltage at pin 13 ( $\bar{Q}$ ) is in the 1 state and is inverted by U17 to cause J (pin 7) to be in the 0 state preventing pin 8 (Q) from being driven.

Upon receipt of one of the time base pulses at pins 1 and 5, pin 12 is driven to the 1 state which permits the 6053 signal gate to open. At the same time pin 13 goes to the 0 state and after being inverted by U17, brings pin 7 (J input) to the 1 state.

The next time base pulse arriving at pins 1 and 5 cannot drive the left-hand flip-flop because pin 3 (K) is held in the 0 state and inhibits the flip-flop.

The time base does drive the right hand flip-flop (pin 5) causing pin 8 ( $\bar{Q}$ ) to be in the 0 state. Pin 10 (J) is grounded so no further inputs will be accepted. Pin 8 now inhibits the signal gate and the 6053 count chain no longer has an input.

#### Transfer Pulse

When the right-hand flip-flop in U16 is driven, Q (pin 9) is driven to the 1 state. This is inverted by the gate function U11 after which it is differentiated by C4 and R24. It passes through CR2 and turns off Q10. A positive pulse appears at the collector of Q10 which transfers the BCD information contained in the count decades to the SN7475 storage packs.

The stored BCD now contained in the SN7475's is converted to 10 line information and drives the gas display tubes V1 thru V9.

#### Reset

Pin 8 of U16 is coupled thru R27 to the base of Q12. At the end of the count period Q12 turns off. C5 is then permitted to begin charging to +15V thru R33. When it reaches about +7V the uni-junction transistor Q13 fires, discharging C5 to ground. A positive pulse is developed across R29 and coupled through R30 to the base of Q14. A reset pulse is generated which drives pin 8 of U16 positive, causing Q12 to turn on and clamp C5 to ground. Now the whole cycle repeats.

#### 4. Count Chain

The count chain consists of U35, U38, U41, U44, U47, U50, U53, and U56. U35 is a SN7490, the remainder are SN7090 decades. The first decade in the count chain is not on the read-out board, but instead, is a separate assembly. In the 6053 the first decade is capable of counting up to 200MHz. The input amplifier and signal gating circuits are included on the separate Amp and Decade assembly.

The output of the first decade comes into the Readout Board at E18 and E19. The signal is amplified by Q4 and Q5; then, drives the input (pin 14) of U35. Pin H of U35 couples to pin 14 of U38, and so on.

The BCD information enters the Readout Board at lugs E11, E12, E13, and E17 where it is stored in U32. The output of U32, when strobed by the control circuitry on pins 4 and 13, is translated to 10-line by U31 (SN7441). The output of U31 grounds one of the ten cathodes at the gas display tube V1 causing a number to glow.

The remaining storage packs (SN7475) are U34, U37, U40, U43, U46, U49, U52, and U55, and operate in the same manner.

## 5. ACTO Computer

The ACTO N computer causes the time base period selected by the front panel resolution switch to be expanded by some factor. Typically that factor will be the harmonic number "N".

When the 0.2-3GHz button is depressed, lug E30 goes to near ground which enables the ACTO +5V power supply. The ACTO +5V enters the readout board at E44. It enables U17 pin 4 and, after being inverted by U18 pin 10 and 11, inhibits U17 pin 1. The effect of this is to prevent the stop flip-flop (U16 pin 9) from being driven until U19 pin 8 goes to the 0 state.

As shown in the timing diagram, the sequence of operation is inhibited by the reset pulse. The decade U23 is first reset to zero; then, counts the 1kHz pulses until it reaches the count of nine, at which time, U17 becomes disabled and the decade counts no further until the next reset pulse.

When the decade (U23) reaches the count of four, pin 8 goes to the 1 state. This enables the gate U12 and raises the JK lines of U28, a dual JK flip-flop, to the 1 state. 1kHz x N pulses are then divided by four in U28. The  $(1\text{kHz} \times N) \div 4$  is then counted by the two cascaded divide-by-16 counters U26 and U27 until U23 reaches the count of 8. At this time U12 is disabled and the JK lines of U28 are grounded. Since  $(1\text{kHz} \times N) \div 4$  has been counted for four periods of 1kHz, N counts will be counted. When U23 reaches the count of 8, pin 1 of U20 and U21 go to the 0 state and return to the 1 state when U23 reaches the count of nine.

When strobed by a negative pulse on pin 1, the integrated divide-by-sixteen counters U20 and U21 are reset to the condition set up by the BCD inputs on pins 4, 10, 3, and 11.

The information contained in U26 and U27 is inverted so that a compliment of the BCD information is applied to the BCD input lines of U20 and U21.

If the number N is 34 then the compliment would be the full capacity of the two divide-by-16 counters minus 34.

When the decade reaches the count of nine, U16 pin 14 goes to the 1 state permitting a start pulse to be accepted. U15 pin 8 goes to the zero state. U15 pins 1, 2, 12, and 13 become enabled permitting the time base pulses to pass through U15 to pin 8 of U20. U20 and U21 then continue to count the time base pulses, triggering on the trailing edge of the pulses. When U20 and U21 reach the condition 1111 or full capacity, pin 8 of U19 goes to the

zero state. This occurs on the trailing edge of a timing pulse. This is inverted by U17 pin 4, 5, and 6 and enables pin 7 of U16 which permits the leading edge of the time base to drive the stop JK flip-flop. Pin 8 of U16 is driven to the zero state and inhibits U15. The preset divide-by-sixteen counters U20 and U21 no longer count the time base.

During the time that the ÷16 preset-reset counters are counting the time base, U15 pin 8, the start line, and U16 pin 9, the stop line are both near ground in the zero state. During this time the counting decades are counting the ACTO VCO frequency.

If  $N = 100$  and the ACTO VCO frequency = 19MHz, then the input frequency is 1900.0MHz or 1.9GHz and will be displayed by the 6053 readout tubes.

#### 4.3.4 200MHz AMP AND DECADE (Schematic D39095)

The 200MHz Amp and Decade circuit description consists of the following sections:

1. X100 Input Attenuator.
2. High input impedance, gain-controlled input stage.
3. Two stages of grounded emitter and two stages of emitter follower amplifier.
4. Schmitt trigger.
5. Signal Gate.
6. 200MHz MECL decade counts with translator to provide TTL BCD logic level output.

The input to the 200MHz Amp and Decade is capacitor-coupled to the input attenuator. This attenuator is controlled by a relay and has an attenuation factor of X1 or X100.

The output of the attenuator is applied to gate 1 of the MOS transistor Q2. This transistor has a voltage gain of 2 or 0.2 and is controlled by the bias on gate 2.

An emitter follower Q3 dc couples this stage to the wide-band amplifier Q5, Q6, Q7, and Q8.

The output of Q8 is applied to the input of the Schmitt trigger, Q9-Q12. The operational amplifier U1, by comparing the dc voltage at the input to the Schmitt trigger, and the voltage at the trigger level pot (R47), adjusts the bias at the base of Q1 to cause the two voltages to become equal.

Two other inputs are provided for the amplifier circuit. One on J2-4 accepts the 1MHz test frequency provided in the 6053. The other, J4 accepts the 20MHz oscillator frequency from the ACTO. When either of these two inputs are used Q2 is turned off by reverse biasing gate 2, thus disabling the normal input.

The Schmitt trigger Q9, Q10, Q11, and Q12 is a conventional high-speed circuit. The input is applied to the base of transistor Q9 which drives emitter follower Q11; then, transistor Q10. The output from Q10 is coupled to the signal gate U2 pin 4 by emitter follower Q12.



The signal gate is turned on and off by applying a voltage at J2-9 and J2-8. A positive (+5V) disables the gate and a ground at these points.

The decade consists of four MECL Flip-Flops U3, U4, U5, and U6. The output of the decade is buffered by the second half of U2 and goes out on J2-5 and J2-6. The MECL BCD logic levels are translated to TTL logic levels by the translator U7.

#### 4.3.5 A5, ACTO (Schematic C39087)

The search oscillator generates the triangular waveform that sweeps the voltage-controlled oscillator (VCO). Transistors Q1 and Q2 form a binary switch. In the following example and with no input present, Q1 conducts while Q2 is held "off". Current flows from the -5.2 volt supply, through Q1 and R9 into the input of amplifier U1 (pin 2). U1 inverts and, due to the feedback network (C2, R5) produces a linear rise in voltage at the output (pin 6). When the output voltage reaches +10V (15 volt difference of potential), CR1 conducts, forward biasing Q2. Q2 now conducts while Q1 is held "off". This action causes the amplifier (U1) to draw current from the positive supply through R12, driving the output in a negative direction until it reaches -5 volts. At -5 volts, Q2 is turned "off" and Q1 is turned "on", repeating the cycle. The net effect is a triangular waveform varying between +10 and -5 volts (TP1).

#### Voltage-Controlled Oscillator ACTO

The triangular waveform is now applied to the base of emitter follower Q3, and into the voltage-controlled oscillator's (VCO) frequency determining tank circuit (CR3, CR4, and L2). CR3 and CR4 are "varicap" type diodes whose capacitance is inversely proportional to the bias applied.

Note that, the varicap curve is nonlinear. To compensate for this nonlinearity, corrective networks consisting of a resistor and a diode in series (R6, CR2, and R3, CR8) are placed across the triangular wave generator load resistor (R15). The effect of these two networks is a nonlinear curve which opposes the varicap curve, resulting in a more linear function.

#### Single-Sideband Generator

The output from the VCO must be shifted in frequency by 1kHz in order to properly drive the "N" channel harmonic mixer, and must be sinusoidal to drive the single-sideband generator.

The VCO signal is obtained from the emitter of Q5, filtered by R23, C31, L6 and C32 to reduce harmonic distortion, and is then split into two components, separated in phase by 90°. Phase separation is accomplished by an LR phase lag circuit (L7, R50) and CR phase lead circuit (C19, R49). The resultant signals are used to drive balanced modulators (U2).

Simultaneously, a 1kHz signal from the time base is routed to the base of Q10. Transistor Q10 inverts and amplifies the signal. A "twin T notch filter" on the collector of Q10 is tuned to block 1kHz, passing all other frequencies. Q11 FET transistor provides a negative feedback path for all frequencies except

1kHz. The remaining 1kHz signal, at the collector of Q11, is now capacitively coupled to the base of phase-splitting amplifier Q8. Two separate 1kHz signals, 90° out-of-phase, are extracted from Q8: The non-inverted signal from the emitter circuit and the 90° leading signal from the emitter of Q9. These signals are capacitively coupled to the balanced modulators in U2. The first balanced modulator removes the carrier frequency, and the second modulator removes one sideband resulting in a single-sideband signal. The net effect of this action is the shifting of the carrier frequency by 1kHz. The balanced modulators (U2) are a pair of differential amplifiers utilizing the carrier to drive the common mode inputs. U3 sums the outputs of the balanced modulators and converts them to a single output.

#### 4.3.6 A6, ACTO MIXER/DRIVER (Schematic C27988)

The mixer/driver assembly consists of two sampling-type mixers, including the local oscillator drive circuits and output amplifiers.

The output of the ACTO VCO is applied to terminal A on the Driver Amp. It is amplified by the differential amplifier/limiter Q101 and Q102. The output is tuned broadly by the  $\pi$  network consisting of C109, L101, and C103. R101 and C107 are the bias network for the step recovery diode CR101.

As the voltage at the anode of CR101 becomes positive CR101 conducts heavily, charging the capacitor C107. When the voltage tries to reverse, the diode CR101 continues to conduct for a time. When it finally reverses, it does so very abruptly. Since all of the current through CR101 has been passing through the printed circuit inductors a voltage transient develops when the current is no longer available. A negative pulse is formed at the anode of CR101 and a positive pulse at the cathode of CR101. These two pulses are approximately 1.2 volts in amplitude and 0.5nsec in width at the base line. They are coupled through C101, X1, P1, and C102, X2, P2 to the mixer P.C. Assy.

This has been a description of the lock channel driver. The N channel driver (Q103, Q104, and CR102) operates in exactly the same manner.

#### Sampling Bridge

The negative pulse from P1 is terminated in R1; then, coupled through C1 to the cathode of CR2.

The positive pulse from P2 is terminated in R2; then, coupled through C2 to the anode at CR1. CR1 and CR2 detect these pulses and set up a positive 0.7 volt bias on the cathode of CR2 and negative bias on the anode of CR1. The voltage at the junction of R5 and R6 is nominally zero volts dc.

The second sampling bridge CR3, CR4, R7, and R8 operates identical to the first.

The RF input signal (200MHz to 3GHz) is applied to the input of both sampling bridges (junction of CR1, CR2, and junction of CR3, CR4). It is then terminated into R9, a 50 $\Omega$  chip resistor.

The output of the lock phase detector bridge is amplified by U1, an operational amplifier. The dual FET Q1 is used as source followers to reduce the signal input current requirement by the amplifier. The output of the amplifier is present at lug "C" on the mixer P.C. board.

To improve the dynamic range of the ACTO and the overload characteristic, an AGC system is used.

CR5 is used as an AGC Detector and detects the level of RF applied to the input of the instrument. The dc voltage drop across CR5 is cancelled out by an opposing voltage drop across CR6. The detected dc voltage is then amplified by the operational amplifier U2. A negative voltage is developed on the output of this amplifier and biases Q3, an N channel FET. Q3 is used as a voltage-controlled resistor which, by altering the negative feed-back, controls the gain of the lock channel amplifier U1.

The dc feed-back network around U2 is designed to have a nonlinear gain curve which matches the voltage to resistance curve of Q3.

The output of U1 on the Mixer P.C. Board goes out to lug "C"; then, through the connecting cable to pin 14 of J2 on the ACTO assembly. There it connects to the input of U1, the search oscillator/amplifier.

When in a phase lock condition, a voltage appears at pin 14, J2 which cancels the current supplied by R9 to pin 2 of U1. Then the search oscillator is over-powered and U1 becomes simply an amplifier.

The N channel amplifier/shaper consists of Q2 and U3. Q2 is a source follower which presents a high impedance load to the N channel phase detector (actually used as a mixer).

Transistor Q2 is followed by an emitter follower; then, a grounded base stage. The output of the grounded base stage drives the Schmitt trigger. The shaped output from the Schmitt trigger drives the grounded emitter amplifier. This last amplifier provides square waves at terminal "X", at TTL logic levels. All the amplifying and shaping is done with five transistors in U3, a transistor array.

The signal at terminal "X" is 1kHz x N. The input of the Schmitt trigger (pin 4 of U3) goes to a lug TP1 and is available as 1kHz x N prior to shaping.

NOTES

CHAPTER 5  
CALIBRATION-MAINTENANCE

### 5.1 INTRODUCTION

This chapter is devoted to maintaining the factory-new performance of the Model 6053 Counter. A calibration procedure, acceptance test and troubleshooting guide have been included for this purpose.

### 5.2 FACTORY SERVICE

Whenever the instrument requires service, other than normal calibration, the nearest Systron-Donner representative should be contacted. He can provide field service or arrange factory service when necessary. Address all inquiries on operation or application to your nearest sales representative, or to:

Sales Manager-Concord Instrument Division  
Systron-Donner Corporation  
888 Galindo Street  
Concord, California 94520

*Be sure to specify the complete model and serial number in all correspondence.*

### 5.3 PART LOCATION

Printed circuit board outline drawings and related parts lists have been included in Chapter 6 to facilitate part identification and location.

### 5.4 CALIBRATION PROCEDURE

The following test equipment is required for calibration and adjustments:

- |                              |                      |                       |
|------------------------------|----------------------|-----------------------|
| (1) Oscilloscope             | Tektronix            | Model 581 A or equiv. |
| (2) Voltmeter                | Systron-Donner       | Model 9000 or equiv.  |
| (3) Voltmeter                | Simpson              | Model 260 or equiv.   |
| (4) 1MHz frequency standard; | 1 part in $10^{-10}$ | short term.           |
| (5) Signal Generator         | H.P.                 | Model 608 E or equiv. |
| (6) RF Voltmeter             | H.P.                 | Model 411 A or equiv. |

#### 5.4.1 Power Supply Adjustments (Schematic C39082)

The following chart indicates the proper supply voltages and their associated adjustment controls. All are located on the Power Supply P.C. Assembly. The SD 9000 DVM is used for these measurements.

TABLE 5.1 POWER SUPPLY ADJUSTMENT

LOCATION	VOLTAGE		TOLERANCE
E20	+15.00	R2 +15 adjust	±.10Vdc
E24	+5.00	R4 +15 adjust	±0.01Vdc
E31	-5.20	R13 -5.2 adjust	±0.01Vdc
E27	-15.00	None (R2 +15 adjust)	±1Vdc
E22	+5.00	R17 ACTO +5 adjust	±0.01Vdc (The 0.2-3GH pushbutton must be depressed.)
E30	+225	None	+80 ±10Vdc as read with the Simpson 260. Voltage is 225V peak but is half-wave rectified, and unfiltered. This accounts for the low voltage reading.

#### 5.4.2 Oscillator Adjustment

Push on TEST pushbutton. Place 1MHz INT/EXT switch to INTERNAL. With oscilloscope (1), triggered by the 1MHz (4) frequency standard; monitor the 1MHz IN-OUT BNC for a 2.5V peak-peak (minimum amplitude) 1MHz rectangular wave. Set COARSE frequency adjustment (counter rear panel) to a position which results in most stationary waveform on scope. Set FINE frequency adjustment (optional oscillators) to position which results in most stationary waveform on scope. Place 1MHz INT-EXT switch to EXT. Oscilloscope should no longer display 1MHz signal. Remove calibration equipment.

#### 5.4.3 200MHz Input Amp and Decade Adjustment (Schematic D39095)

1. Push the power switch on and depress the X1 ATTENUATOR button.
2. Apply 200MHz at a level of 10 millivolts. This is measured at the front panel as shown in Figure 5.1.
3. With the Resolution switch in 100kHz position, adjust R47 to obtain a good stable reading. Reduce the input level, and repeat the adjustment to find the optimum setting.
4. Note the input voltage level that is required for a stable reading. Increase this level ten times.
5. Depress the X10 ATTENUATOR button and adjust R50 until the 6053 just barely counts correctly. Reduce the input level and then increase it to the original X10 level. The 6053 should again present a stable correct reading. The level required should not exceed 100 millivolts.

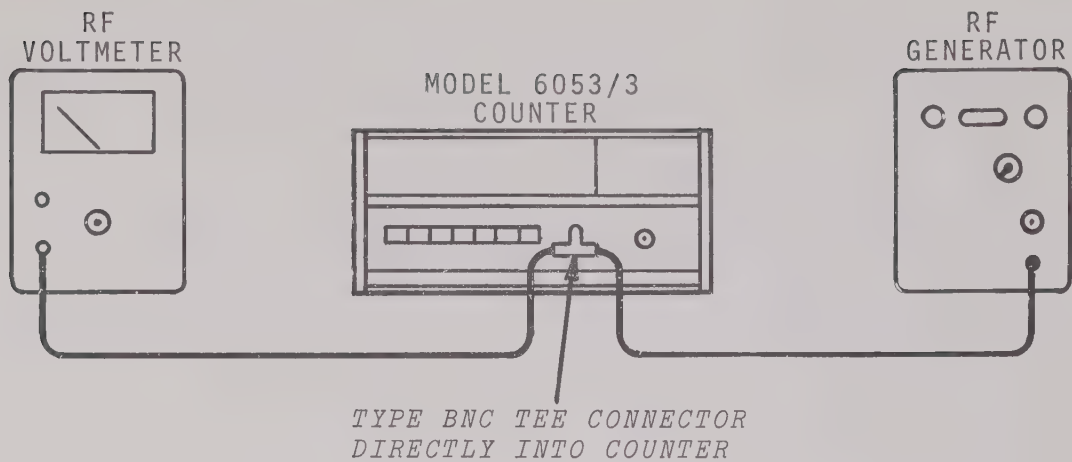

FIGURE 5.1 VOLTAGE MEASUREMENT OF RF INPUT

6. Depress the X100 ATTENUATOR button; then, increase the generator output level another ten times.
7. Adjust C5 so that the 6053 just barely gives a good stable reading. (In later instruments, C5 is not adjustable.)

#### 5.4.4 ACTO ADJUSTMENT (Schematic C39087)

##### Mixer Balance

1. With no input connected to the 6053, depress the .2 - 3GHz button.
2. Observe the waveform present at TP1 on the ACTO Assy (A5). This should be a symmetrical triangular waveform swinging between +10 and -5 volts.
3. Adjust R17 on the mixer assembly (A6), if necessary, to make the waveform symmetrical.

##### Gain Set

1. Set the resolution switch to  $10^{-3}$  (1kHz) or  $10^{-4}$  (10kHz) resolution.
2. Apply 3GHz at a level of 50mV rms (-13dBm) to the .2 - 3GHz input of the 6053.
3. Adjust the gain control R24 on the ACTO Assy (A5), so that 6053 correctly indicates the input frequency.

#### 5.5 BOARD REPAIR

##### NOTE

READ BEFORE CHANGING ANY COMPONENT ON A  
PRINTED-CIRCUIT BOARD

When replacing integrated circuits or other electronic components soldered to printed-circuit boards, the procedures indicated below must be followed or damage to the board may result:

1. Determine by troubleshooting techniques, which integrated circuit or discrete component(s) has failed.
2. Remove the defective component(s) from the board by cutting the pins or leads with a small diagonal clipping tool. (Always remove and replace the entire component.)
3. Apply heat (40-50W soldering iron) sparingly to each of the cut pins or leads and remove from the board; clean the hole(s) with a toothpick or solder suction tool.
4. Form the tinned leads of the replacement part and insert in the printed circuit holes; solder, then trim leads to extend 1/16-inch beyond the back surface of the board. (Use only 63-37 solder with maximum 1/16-inch diameter.)

#### CAUTION

*Always trim semiconductor leads only after soldered installation is complete. This procedure greatly lessens the possibility of component failure due to shock-wave damage caused by the trimming tool.*

5. When soldering semiconductor devices and all small components, be sure to use a heat sink tool or long-nosed plier connected to the component lead(s) while each is being soldered. Allow the soldered connection to cool before removing the heat sink.
6. Clean all dirt and solder-flux from the printed circuit traces by liberal application of isopropyl alcohol or freon-type solvents.



CHAPTER 6  
DRAWINGS AND PARTS LISTS

6.1 INTRODUCTION

This chapter contains the drawings and parts lists for the SD Model 6053 Frequency Counter. Each section is composed of an assembly, schematic, and a parts list. All sections are arranged in assembly sequence, with the exception of the Block Diagram, and the Block Diagram Parts List - these items follow immediately after this introduction.

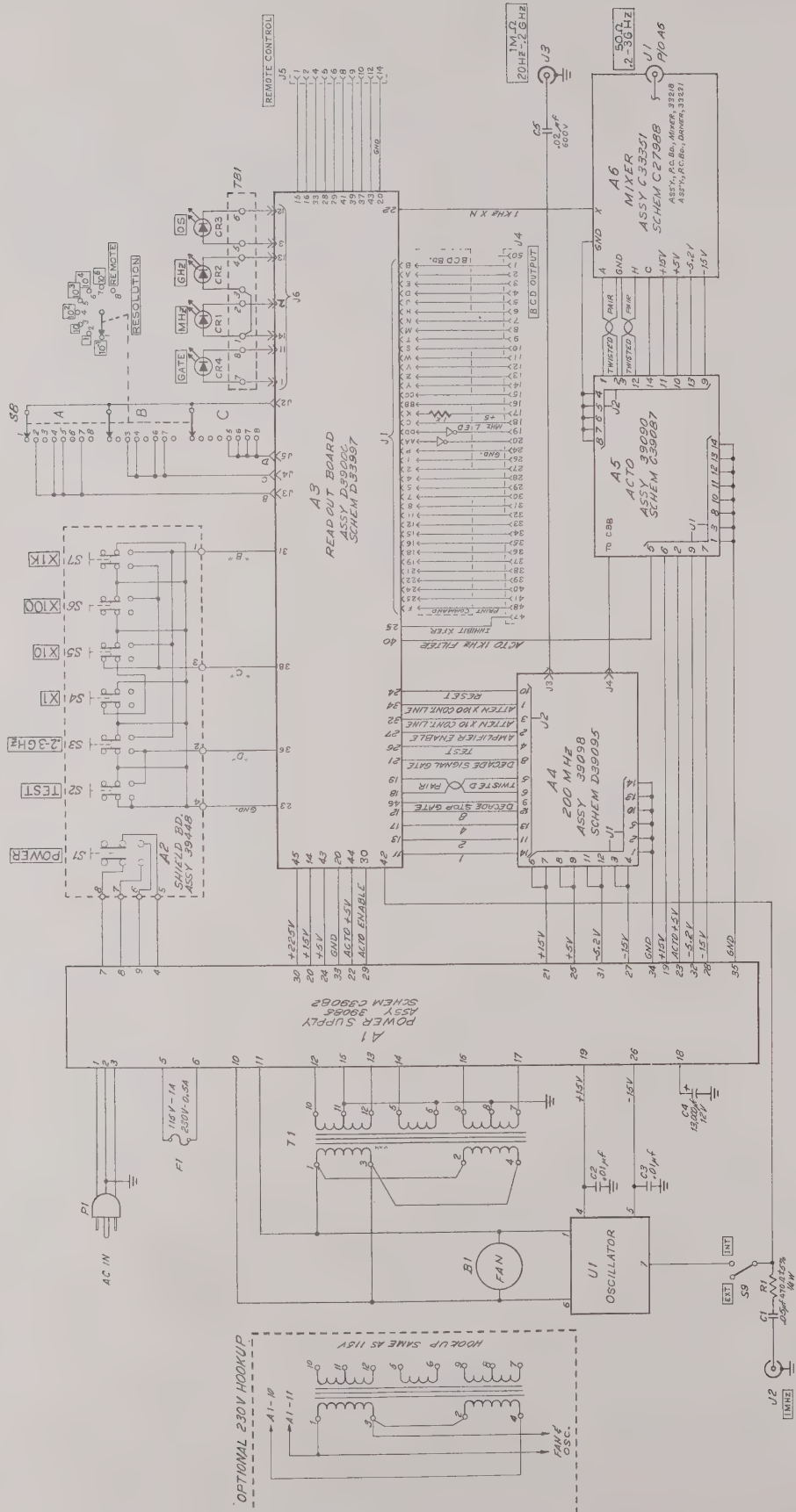

MODEL 6053/3 INTERCONNECT DIAGRAM, D39100R3

BLOCK DIAGRAM PARTS LIST

REF.	DESCRIPTION	SD PART NO.
	Block Diagram, Model 6053/3	D39100R3
B1	Blower	H1786
C1	Capacitor, .05 $\mu$ F, 12V	C0672
C2	Capacitor, .01 $\mu$ F, 100V	C0556
C3	Capacitor, .01 $\mu$ F, 100V	C0556
C4	Capacitor, 13K $\mu$ F, 12V	C1122
C5	Capacitor, .02 $\mu$ F, 600V	C0421
CR1	Assembly Lamp, Light Emitting	CR0367
CR2	Assembly Lamp, Light Emitting	CR0367
CR3	Assembly Lamp, Light Emitting	CR0367
CR4	Assembly Lamp, Light Emitting	CR0367
F1	Fuse, 1A, 3AG	F0001
J1	Connector, Female, Type N	J0552
J2	Connector, BNC	J0165
J3	Connector, BNC	J0260
J4	Connector, 50 Pin	J0170
J5	Connector, 14 Pin	J0310
P1	Line Cord	W0076
R1	Resistor, 470 $\Omega$ , 1/4W, 5%	R1044
S8	Assembly switch, Resolution	39451
S9	Switch, Toggle, SPDT	S0149
T1	Transformer	39207
U1	Oscillator	33151
	Filter, Polaroid	33922
	Filter, Foam	39410
	Fuse Holder, 3AG	X0034
	Knob	45011360
	Socket, Octal	X0004
	Acto Cable Assy	59469
	Acto Mixer, Cable Assy	29475
	Connector, IC	J0605
	Recept. AMP 60939-1	

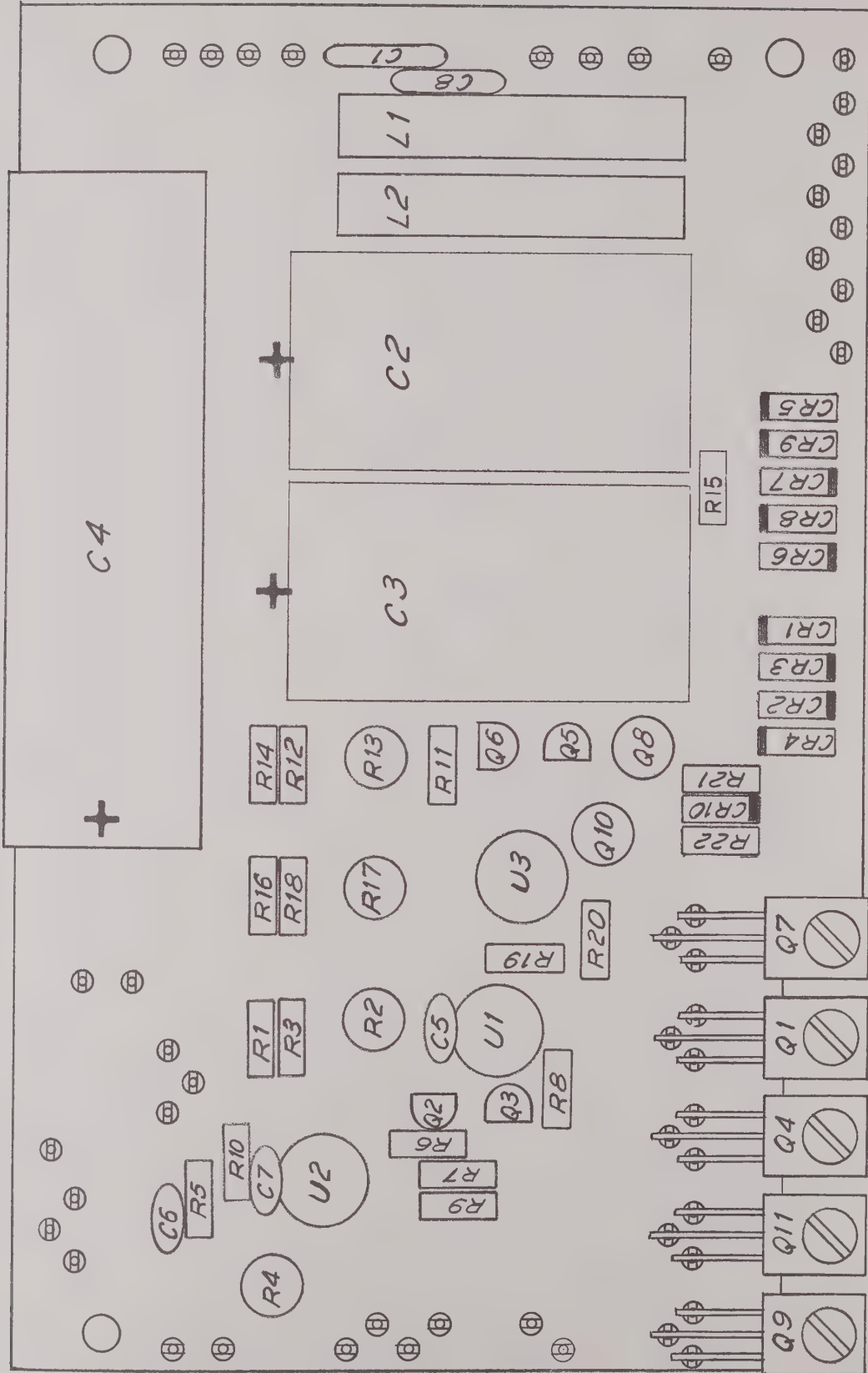

A1, POWER SUPPLY ASSEMBLY, D39085R2

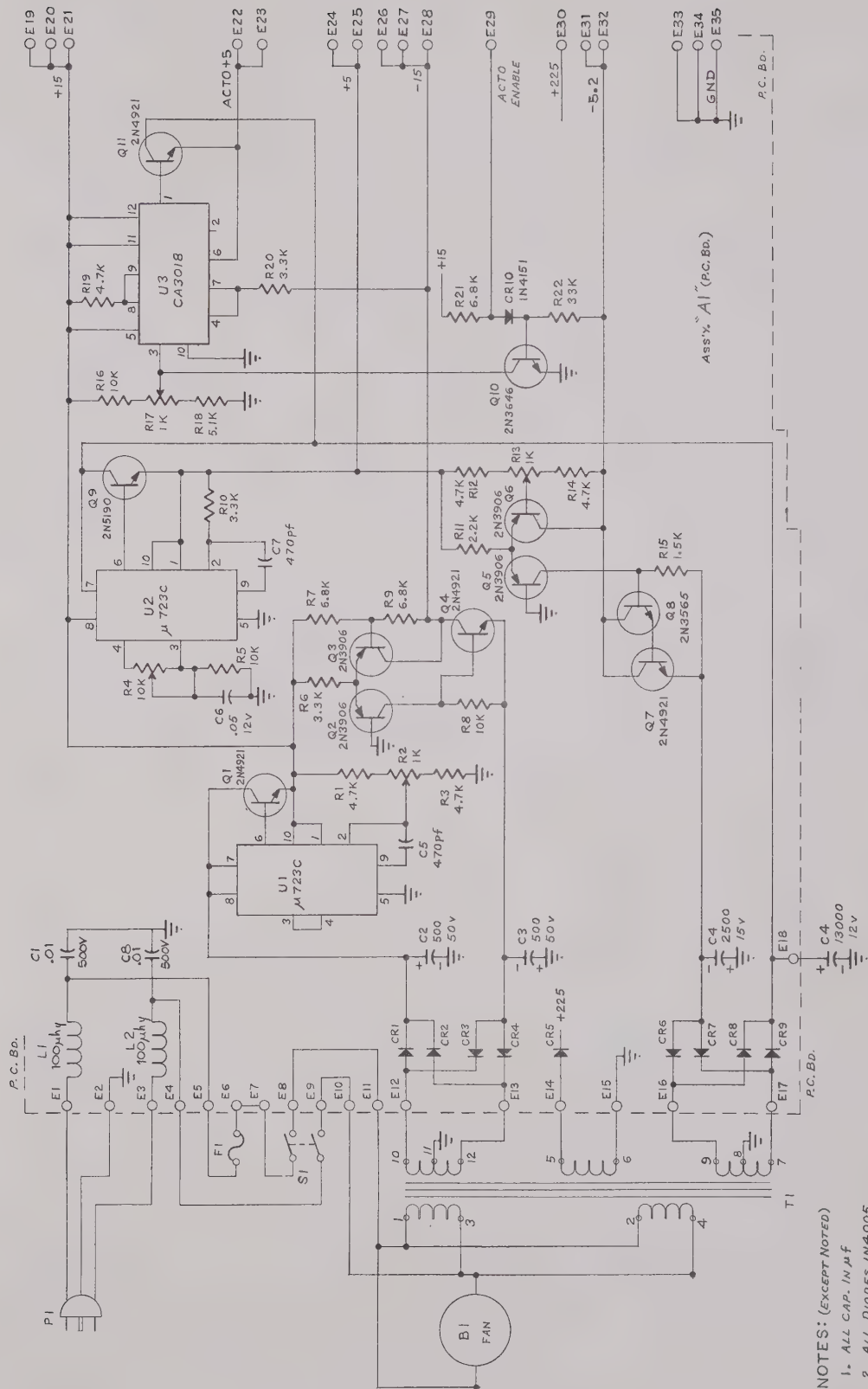

Ass'y. A1 (P.C. Bd.)

- NOTES: (EXCEPT NOTED)
1. ALL CAP. IN  $\mu$ f
  2. ALL DIODES IN 4-005
  3. ALL RES.  $\frac{1}{4}$ W, 5%

A1, POWER SUPPLY SCHEMATIC, C39082R2

# A1 POWER SUPPLY PARTS LIST

REF.	DESCRIPTION	SD PART NO.
	A1 Power Supply P.C. Assembly	D39085R2
	A1 Power Supply Schematic	C39082R2
C1	Capacitor, .01 $\mu$ F, 500V	C0423
C2	Capacitor, 500 $\mu$ F, 50V	C1243
C3	Capacitor, 500 $\mu$ F, 50V	C1243
C4	Capacitor, 2500 $\mu$ F, 15V	C1148
C5	Capacitor, 470pF	C0542
C6	Capacitor, .05 $\mu$ F, 12V	C0672
C7	Capacitor, 470pF	C0542
C8	Capacitor, .01 $\mu$ F, 500V	C0423
CR1	Diode, 1N4005	CR0284
CR2	Diode, 1N4005	CR0284
CR3	Diode, 1N4005	CR0284
CR4	Diode, 1N4005	CR0284
CR5	Diode, 1N4005	CR0284
CR6	Diode, 1N4005	CR0284
CR7	Diode, 1N4005	CR0284
CR8	Diode, 1N4005	CR0284
CR9	Diode, 1N4005	CR0284
CR10	Diode, 1N4151	CR0150
L1	Inductor, 100 $\mu$ H, $\pm$ 20%	L0166
L2	Inductor, 100 $\mu$ H, $\pm$ 20%	L0166
Q1	Transistor, 2N4921	Q0267
Q2	Transistor, 2N3906	Q0248
Q3	Transistor, 2N3906	Q0248
Q4	Transistor, 2N4921	Q0267
Q5	Transistor, 2N3906	Q0248
Q6	Transistor, 2N3906	Q0248
Q7	Transistor, 2N4921	Q0267
Q8	Transistor, 2N3565	Q0237
Q9	Transistor, 2N5190	Q0281
Q10	Transistor, 2N3646	Q0218
Q11	Transistor, 2N4921	Q0267
R1	Resistor, 4.7K, 1/4W, 5%	R0892
R2	Resistor, VAR., 1K	R2390
R3	Resistor, 4.7K, 1/4W, 5%	R0892
R4	Resistor, VAR., 10K	R2383
R5	Resistor, 10K, 1/4W, 5%	R0766

## A1 POWER SUPPLY PARTS LIST (Cont'd)

REF.	DESCRIPTION	SD PART NO.
R6	Resistor, 3.3K, 1/4W, 5%	R0742
R7	Resistor, 6.8K, 1/4W, 5%	R0696
R8	Resistor, 10K, 1/4W, 5%	R0766
R9	Resistor, 6.8K, 1/4W, 5%	R0696
R10	Resistor, 3.3K, 1/4W, 5%	R0742
R11	Resistor, 2.2K, 1/4W, 5%	R0794
R12	Resistor, 4.7K, 1/4W, 5%	R0892
R13	Resistor, VAR., 1K	R2390
R14	Resistor, 4.7K, 1/4W, 5%	R0892
R15	Resistor, 1.5K, 1/4W, 5%	R0783
R16	Resistor, 10K, 1/4W, 5%	R0766
R17	Resistor, VAR., 1K	R2390
R18	Resistor, 5.1K, 1/4W, 5%	R0693
R19	Resistor, 4.7K, 1/4W, 5%	R0892
R20	Resistor, 3.3K, 1/4W, 5%	R0742
R21	Resistor, 6.8K, 1/4W, 5%	R0696
R22	Resistor, 33K, 1/4W, 5%	R0780
U1	Integrated Circuit, $\mu$ 723C	25756
U2	Integrated Circuit, $\mu$ 723C	25756
U3	Integrated Circuit, CA3018	25720

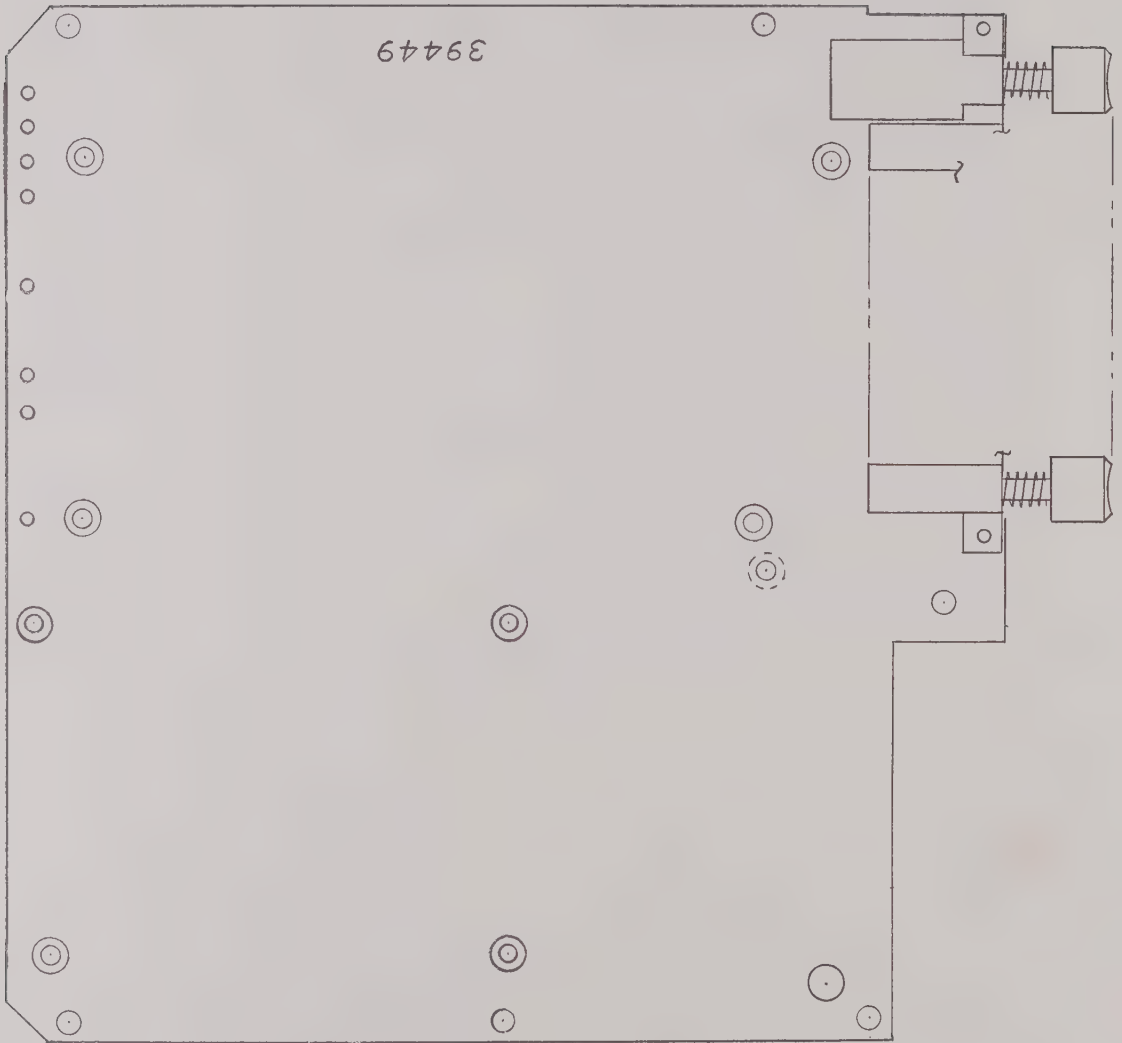

A2, SHIELD BOARD ASSEMBLY, C39448R2



# A2 SHIELD PARTS LIST

REF.	DESCRIPTION	SD PART NO.
	A2 Shield P.C. Assembly	C39448R2
	A2 Shield Schematic	P/O D39100R3
S1	Switch, Pushbutton, 7 STA W/Buttons	S0392
S2	Switch, Pushbutton, 7 STA W/Buttons	S0392
S3	Switch, Pushbutton, 7 STA W/Buttons	S0392
S4	Switch, Pushbutton, 7 STA W/Buttons	S0392
S5	Switch, Pushbutton, 7 STA W/Buttons	S0392
S6	Switch, Pushbutton, 7 STA W/Buttons	S0392
S7	Switch, Pushbutton, 7 STA W/Buttons	S0392

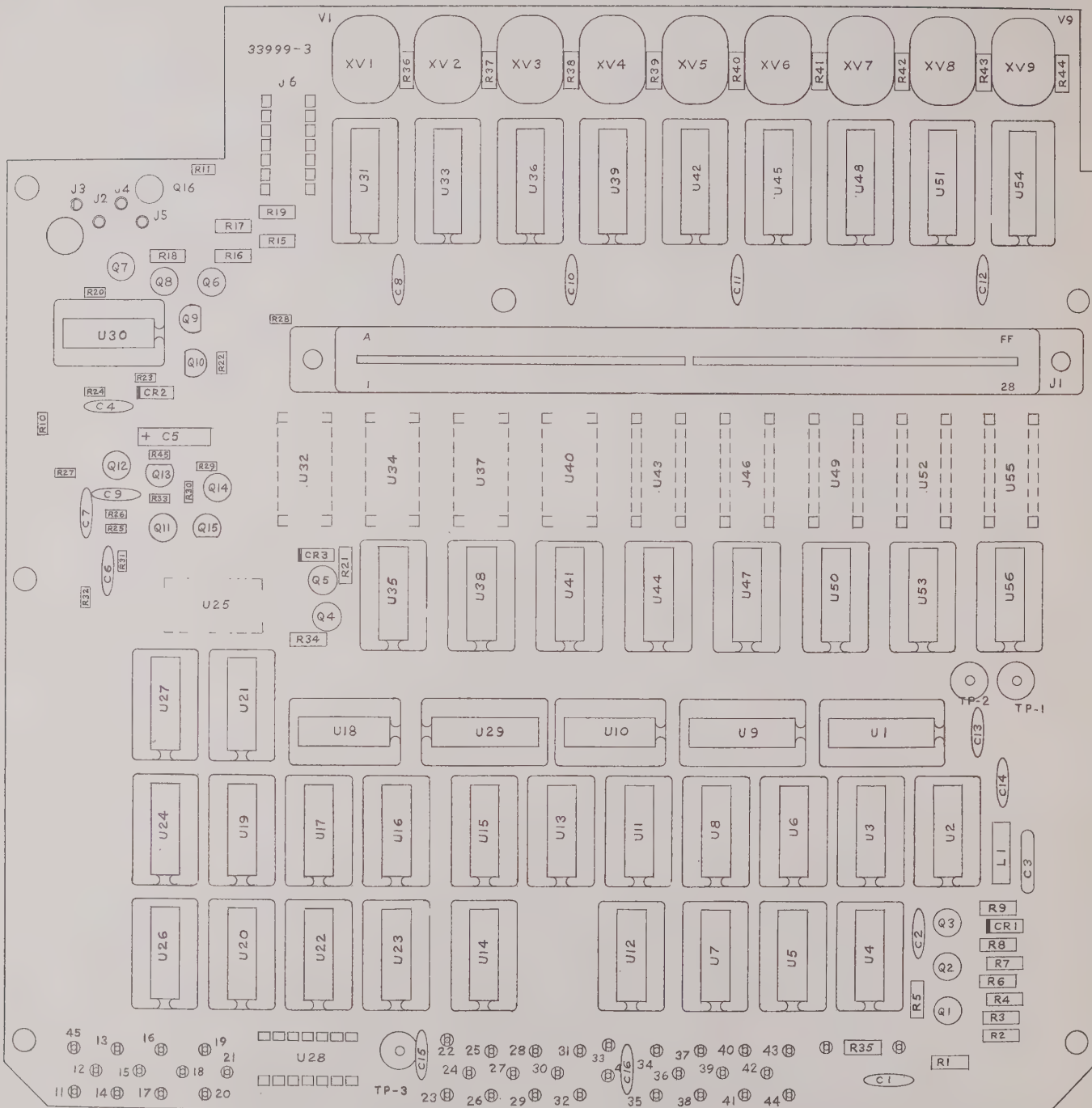

A3, READOUT P.C. ASSEMBLY, D39000R2

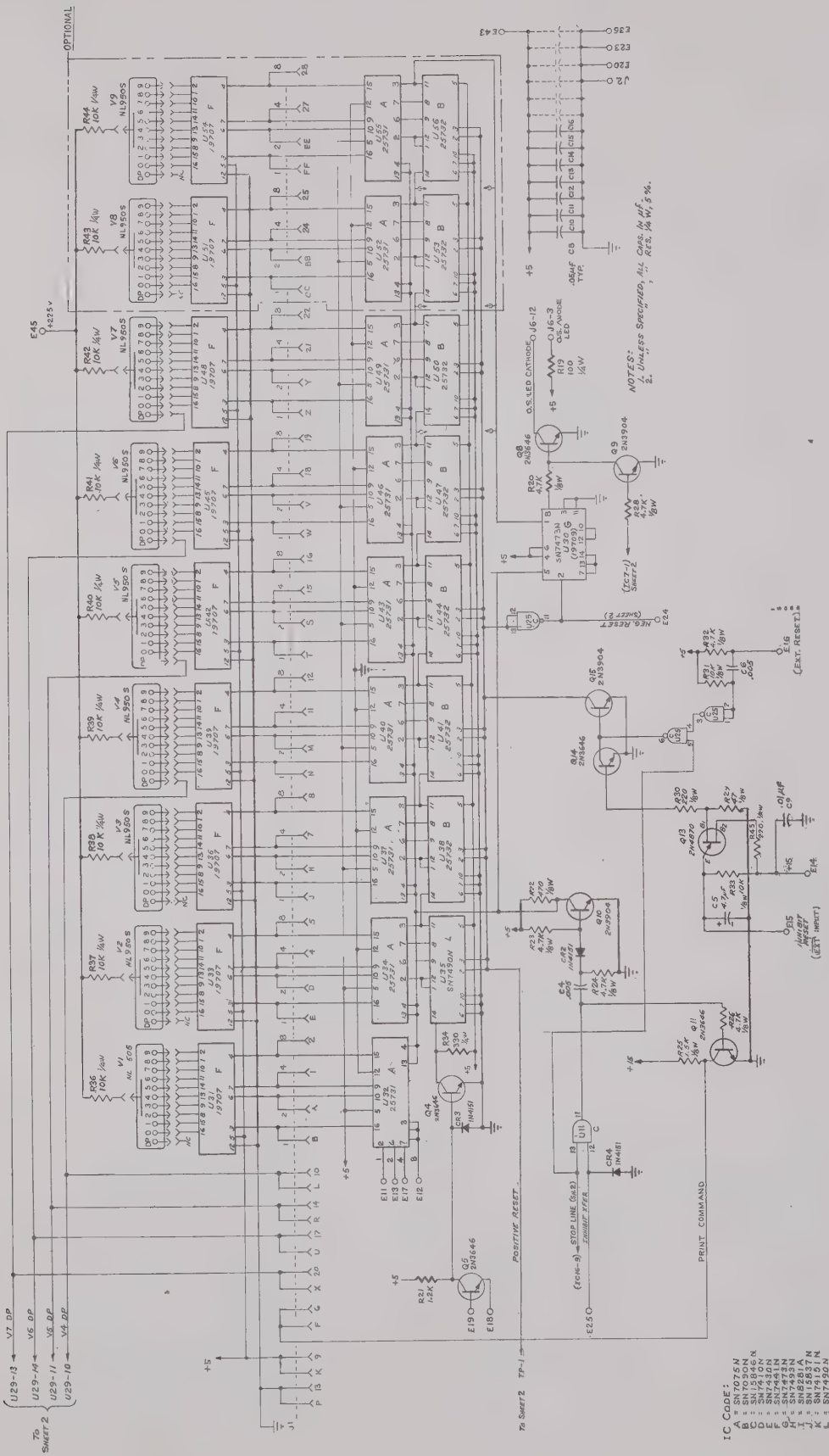

A3, READOUT SCHEMATIC, SHEET 1 OF 2, D33997R4

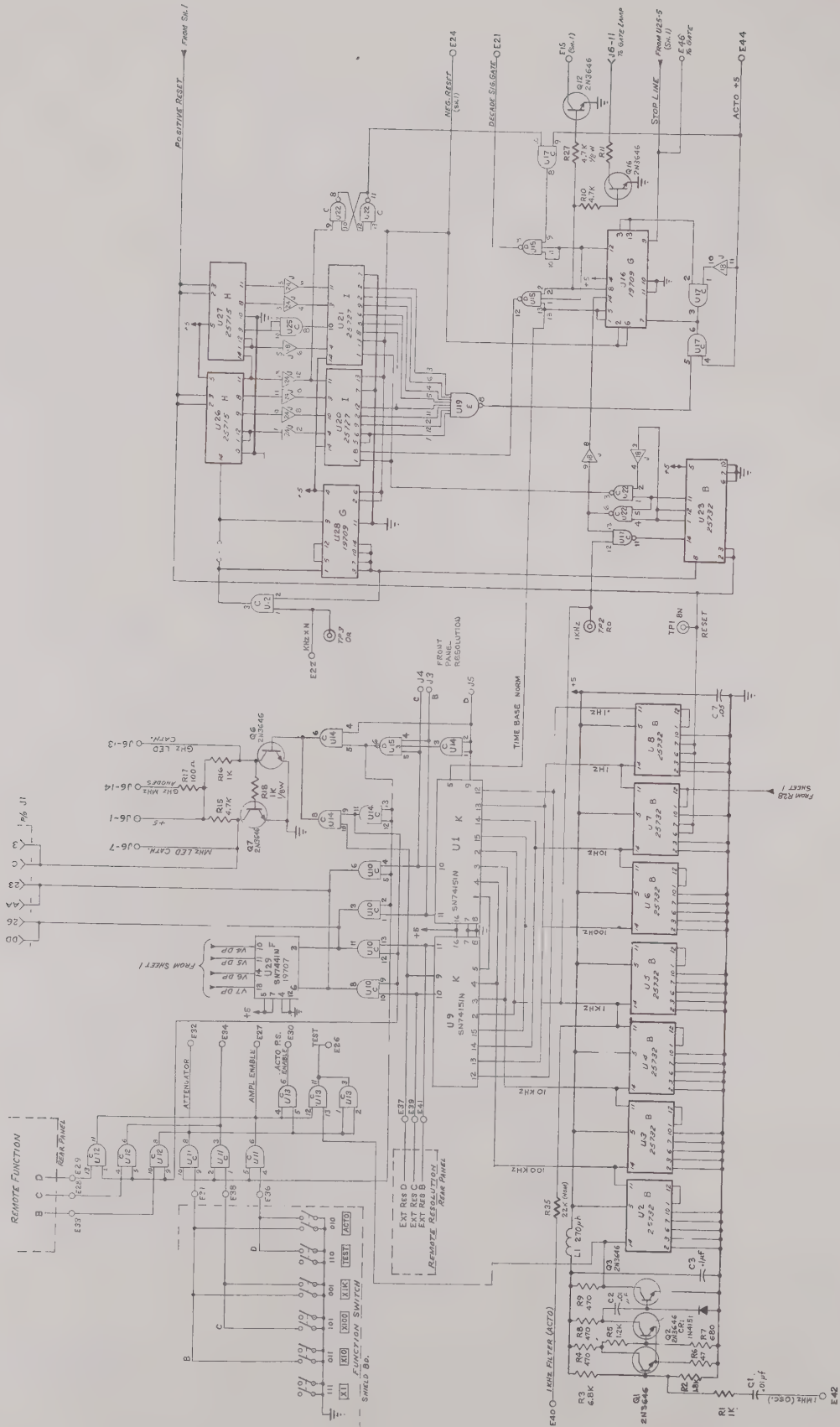

A3, READOUT SCHEMATIC, SHEET 2 OF 2, D33997R4

## A3 READOUT BOARD PARTS LIST

REF.	DESCRIPTION	SD PART NO.
	A3 Readout Board P.C. Assembly	D39000R2
	A3 Readout Board Schematic	D33997R4
C1	Capacitor, .01 $\mu$ F, 100V	C0556
C2	Capacitor, .01 $\mu$ F, 100V	C0556
C3	Capacitor, .1 $\mu$ F, 50V	C0881
C4	Capacitor, .005 $\mu$ F, 150V	C0325
C5	Capacitor, 4.7 $\mu$ F	C0406
C6	Capacitor, .005 $\mu$ F, 150V	C0325
C7	Capacitor, .05 $\mu$ F, 12V, Disc	C0672
C8	Capacitor, .05 $\mu$ F, 12V, Disc	C0672
C9	Capacitor, .01 $\mu$ F, 100V	C0556
C10	Capacitor, .05 $\mu$ F, 12V, Disc	C0672
C11	Capacitor, .05 $\mu$ F, 12V, Disc	C0672
C12	Capacitor, .05 $\mu$ F, 12V, Disc	C0672
C13	Capacitor, .05 $\mu$ F, 12V, Disc	C0672
C14	Capacitor, .05 $\mu$ F, 12V, Disc	C0672
C15	Capacitor, .05 $\mu$ F, 12V, Disc	C0672
C16	Capacitor, .05 $\mu$ F, 12V, Disc	C0672
CR1	Diode, 1N4151	CR0150
CR2	Diode, 1N4151	CR0150
CR3	Diode, 1N4151	CR0150
CR4	Diode, 1N4151	CR0150
J1	Connector, P.C., 28/56, 2VH28/1AV5	09060800
J2	Connector, Post, AMP 61067-1	E0318
J3	Connector, Post, AMP 61067-1	E0318
J4	Connector, Post, AMP 61067-1	E0318
J5	Connector, Post, AMP 61067-1	E0318
J6	Connector, Socket, I.C., 7 Term	X0184
L1	Inductor, 270 $\mu$ H	L0067
Q1	Transistor, 2N3646	Q0218
Q2	Transistor, 2N3646	Q0218
Q3	Transistor, 2N3646	Q0218
Q4	Transistor, 2N3646	Q0218
Q5	Transistor, 2N3646	Q0218
Q6	Transistor, 2N3646	Q0218
Q7	Transistor, 2N3646	Q0218
Q8	Transistor, 2N3646	Q0218
Q9	Transistor, 2N3904	Q0247
Q10	Transistor, 2N3904	Q0247

A3 READOUT BOARD PARTS LIST (Cont'd)

REF.	DESCRIPTION	SD PART NO.
Q11	Transistor, 2N3646	Q0218
Q12	Transistor, 2N3646	Q0218
Q13	Transistor, 2N4870	Q0266
Q14	Transistor, 2N3646	Q0218
Q15	Transistor, 2N3904	Q0247
Q16	Transistor, 2N3646	Q0218
R1	Resistor, 1K, 1/4W, 5%	R0765
R2	Resistor, 1.8K, 1/4W, 5%	R0959
R3	Resistor, 6.8K, 1/4W, 5%	R0696
R4	Resistor, 470 $\Omega$ , 1/4W, 5%	R1044
R5	Resistor, 1.2K, 1/4W, 5%	R0809
R6	Resistor, 47 $\Omega$ , 1/4W, 5%	R0743
R7	Resistor, 680 $\Omega$ , 1/4W, 5%	R1234
R8	Resistor, 470 $\Omega$ , 1/4W, 5%	R1044
R9	Resistor, 470 $\Omega$ , 1/4W, 5%	R1044
R10	Resistor, 4.7K, 1/8W, 5%	R1733
R11	Resistor, Factory Selected	Rxxxx
R12	Not Used	
R13	Not Used	
R14	Not Used	
R15	Resistor, 4.7K, 1/4W, 5%	R0892
R16	Resistor, 1K, 1/4W, 5%	R0765
R17	Resistor, 100 $\Omega$ , 1/4W, 5%	R0966
R18	Resistor, 1K, 1/4W, 5%	R0765
R19	Resistor, 100 $\Omega$ , 1/4W, 5%	R0966
R20	Resistor, 4.7K, 1/8W, 5%	R1733
R21	Resistor, 1.2K, 1/4W, 5%	R0809
R22	Resistor, 470 $\Omega$ , 1/8W, 5%	R1451
R23	Resistor, 4.7K, 1/8W, 5%	R1733
R24	Resistor, 4.7K, 1/8W, 5%	R1733
R25	Resistor, 1.5K, 1/8W, 5%	R2463
R26	Resistor, 4.7K, 1/8W, 5%	R1733
R27	Resistor, 4.7K, 1/8W, 5%	R1733
R28	Resistor, 4.7K, 1/8W, 5%	R1733
R29	Resistor, 47 $\Omega$ , 1/8W, 5%	R1449
R30	Resistor, 220 $\Omega$ , 1/8W, 5%	R1743
R31	Resistor, 10K, 1/8W, 5%	R1437
R32	Resistor, 4.7K, 1/8W, 5%	R1733
R33	Resistor, 10K, 1/8W, 5%	R1437
R34	Resistor, 330 $\Omega$ , 1/4W, 5%	R0662
R35	Resistor, 22K, 1/4W, 5%	R0768

## A3 READOUT BOARD PARTS LIST (Cont'd)

REF	DESCRIPTION	SD PART NO.
R36	Resistor, 10K, 1/4W, 5%	R0766
R37	Resistor, 10K, 1/4W, 5%	R0766
R38	Resistor, 10K, 1/4W, 5%	R0766
R39	Resistor, 10K, 1/4W, 5%	R0766
R40	Resistor, 10K, 1/4W, 5%	R0766
R41	Resistor, 10K, 1/4W, 5%	R0766
R42	Resistor, 10K, 1/4W, 5%	R0766
R43	Resistor, 10K, 1/4W, 5%	R0766
R44	Resistor, 10K, 1/4W, 5%	R0766
R45	Resistor, 220 $\Omega$ , 1/8W, 5%	R1743
U1	Integrated Circuit, SN74151N	
U2	Integrated Circuit, SN7090N	25732
U3	Integrated Circuit, SN7090N	25732
U4	Integrated Circuit, SN7090N	25732
U5	Integrated Circuit, SN7090N	25732
U6	Integrated Circuit, SN7090N	25732
U7	Integrated Circuit, SN7090N	25732
U8	Integrated Circuit, SN7090N	25732
U9	Integrated Circuit, SN74151N	
U10	Integrated Circuit, SN15846	19716
U11	Integrated Circuit, SN15846	19716
U12	Integrated Circuit, SN15846	19716
U13	Integrated Circuit, SN15846	19716
U14	Integrated Circuit, SN15846	19716
U15	Integrated Circuit, SN7410N	19706
U16	Integrated Circuit, SN7473N	19709
U17	Integrated Circuit, SN15846	19716
U18	Integrated Circuit, SN15837N	25728
U19	Integrated Circuit, SN7430N	25726
U20	Integrated Circuit, SN8281A	25727
U21	Integrated Circuit, SN8281A	25727
U22	Integrated Circuit, SN15846	19716
U23	Integrated Circuit, SN7090N	25732
U24	Integrated Circuit, SN15837N	25728
U25	Integrated Circuit, SN15846	19716
U26	Integrated Circuit, SN7493N	25715
U27	Integrated Circuit, SN7493N	25715
U28	Integrated Circuit, SN7473N	19709
U29	Integrated Circuit, SN7441N	19707
U30	Integrated Circuit, SN7473N	19709

A3 READOUT BOARD PARTS LIST (Cont'd)

REF.	DESCRIPTION	SD PART NO.
U31	Integrated Circuit, SN7441N	19707
U32	Integrated Circuit, SN7075N	25731
U33	Integrated Circuit, SN7441N	19707
U34	Integrated Circuit, SN7075N	25731
U35	Integrated Circuit, SN7490N	19711
U36	Integrated Circuit, SN7441N	19707
U37	Integrated Circuit, SN7075N	25731
U38	Integrated Circuit, SN7090N	25732
U39	Integrated Circuit, SN7441N	19707
U40	Integrated Circuit, SN7075N	25731
U41	Integrated Circuit, SN7090N	25732
U42	Integrated Circuit, SN7441N	19707
U43	Integrated Circuit, SN7075N	25731
U44	Integrated Circuit, SN7090N	25732
U45	Integrated Circuit, SN7441N	19707
U46	Integrated Circuit, SN7075N	25731
U47	Integrated Circuit, SN7090N	25732
U48	Integrated Circuit, SN7441N	19707
U49	Integrated Circuit, SN7075N	25731
U50	Integrated Circuit, SN7090N	25732
U51	Integrated Circuit, SN7441N	19707
U52	Integrated Circuit, SN7075N	25731
U53	Integrated Circuit, SN7090N	25732
U54	Integrated Circuit, SN7441N	19707
U55	Integrated Circuit, SN7075N	25731
U56	Integrated Circuit, SN7090N	25732
V1	Tube, Readout, NL5859S	V0131
V2	Tube, Readout, NL5859S	V0131
V3	Tube, Readout, NL5859S	V0131
V4	Tube, Readout, NL5859S	V0131
V5	Tube, Readout, NL5859S	V0131
V6	Tube, Readout, NL5859S	V0131
V7	Tube, Readout, NL5859S	V0131
V8	Tube, Readout, NL5859S	V0131
V9	Tube, Readout, NL5859S	V0131
XU1	Integrated Circuit Socket, 8 Term	X0185
XU2	Integrated Circuit Socket, 7 Term	X0184
XU3	Integrated Circuit Socket, 7 Term	X0184
XU4	Integrated Circuit Socket, 7 Term	X0184
XU5	Integrated Circuit Socket, 7 Term	X0184



## A3 READOUT BOARD PARTS LIST (Cont'd)

REF.	DESCRIPTION	SD PART NO.
XU6	Integrated Circuit Socket, 7 Term	X0184
XU7	Integrated Circuit Socket, 7 Term	X0184
XU8	Integrated Circuit Socket, 7 Term	X0184
XU9	Integrated Circuit Socket, 8 Term	X0185
XU10	Integrated Circuit Socket, 7 Term	X0184
XU11	Integrated Circuit Socket, 7 Term	X0184
XU12	Integrated Circuit Socket, 7 Term	X0184
XU13	Integrated Circuit Socket, 7 Term	X0184
XU14	Integrated Circuit Socket, 7 Term	X0184
XU15	Integrated Circuit Socket, 7 Term	X0184
XU16	Integrated Circuit Socket, 7 Term	X0184
XU17	Integrated Circuit Socket, 7 Term	X0184
XU18	Integrated Circuit Socket, 7 Term	X0184
XU19	Integrated Circuit Socket, 7 Term	X0184
XU20	Integrated Circuit Socket, 7 Term	X0184
XU21	Integrated Circuit Socket, 7 Term	X0184
XU22	Integrated Circuit Socket, 7 Term	X0184
XU23	Integrated Circuit Socket, 7 Term	X0184
XU24	Integrated Circuit Socket, 7 Term	X0184
XU25	Integrated Circuit Socket, 7 Term	X0184
XU26	Integrated Circuit Socket, 7 Term	X0184
XU27	Integrated Circuit Socket, 7 Term	X0184
XU28	Integrated Circuit Socket, 7 Term	X0184
XU29	Integrated Circuit Socket, 8 Term	X0185
XU30	Integrated Circuit Socket, 7 Term	X0184
XU31	Integrated Circuit Socket, 8 Term	X0185
XU32	Integrated Circuit Socket, 8 Term	X0185
XU33	Integrated Circuit Socket, 8 Term	X0185
XU34	Integrated Circuit Socket, 8 Term	X0185
XU35	Integrated Circuit Socket, 7 Term	X0184
XU36	Integrated Circuit Socket, 8 Term	X0185
XU37	Integrated Circuit Socket, 8 Term	X0185
XU38	Integrated Circuit Socket, 7 Term	X0184
XU39	Integrated Circuit Socket, 8 Term	X0185
XU40	Integrated Circuit Socket, 8 Term	X0185
XU41	Integrated Circuit Socket, 7 Term	X0184
XU42	Integrated Circuit Socket, 8 Term	X0185
XU43	Integrated Circuit Socket, 8 Term	X0185
XU44	Integrated Circuit Socket, 7 Term	X0184
XU45	Integrated Circuit Socket, 8 Term	X0185

## A3 READOUT BOARD PARTS LIST (Cont'd)

REF	DESCRIPTION	SD PART NO.
XU46	Integrated Circuit Socket, 8 Term	X0185
XU47	Integrated Circuit Socket, 7 Term	X0184
XU48	Integrated Circuit Socket, 8 Term	X0185
XU49	Integrated Circuit Socket, 8 Term	X0185
XU50	Integrated Circuit Socket, 7 Term	X0184
XU51	Integrated Circuit Socket, 8 Term	X0185
XU52	Integrated Circuit Socket, 8 Term	X0185
XU53	Integrated Circuit Socket, 7 Term	X0184
XU54	Integrated Circuit Socket, 8 Term	X0185
XU55	Integrated Circuit Socket, 8 Term	X0185
XU56	Integrated Circuit Socket, 7 Term	X0184
XV1	Socket, Tube, RTS-44	X0179
XV2	Socket, Tube, RTS-44	X0179
XV3	Socket, Tube, RTS-44	X0179
XV4	Socket, Tube, RTS-44	X0179
XV5	Socket, Tube, RTS-44	X0179
XV6	Socket, Tube, RTS-44	X0179
XV7	Socket, Tube, RTS-44	X0179
XV8	Socket, Tube, RTS-44	X0179
XV9	Socket, Tube, RTS-44	X0179

NOTES

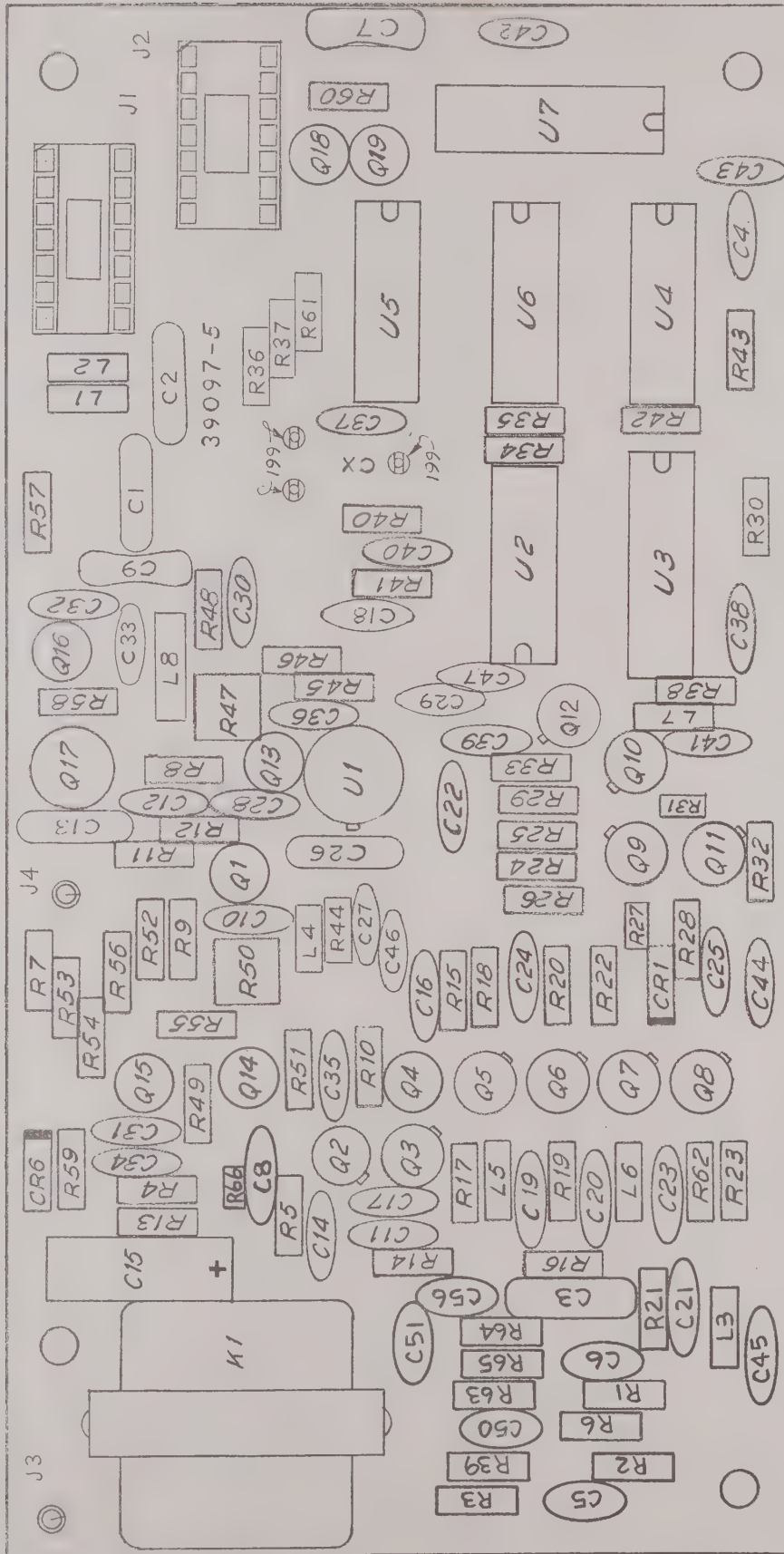

A4, 200MHZ AMP & DECADE ASSEMBLY, D39098R5

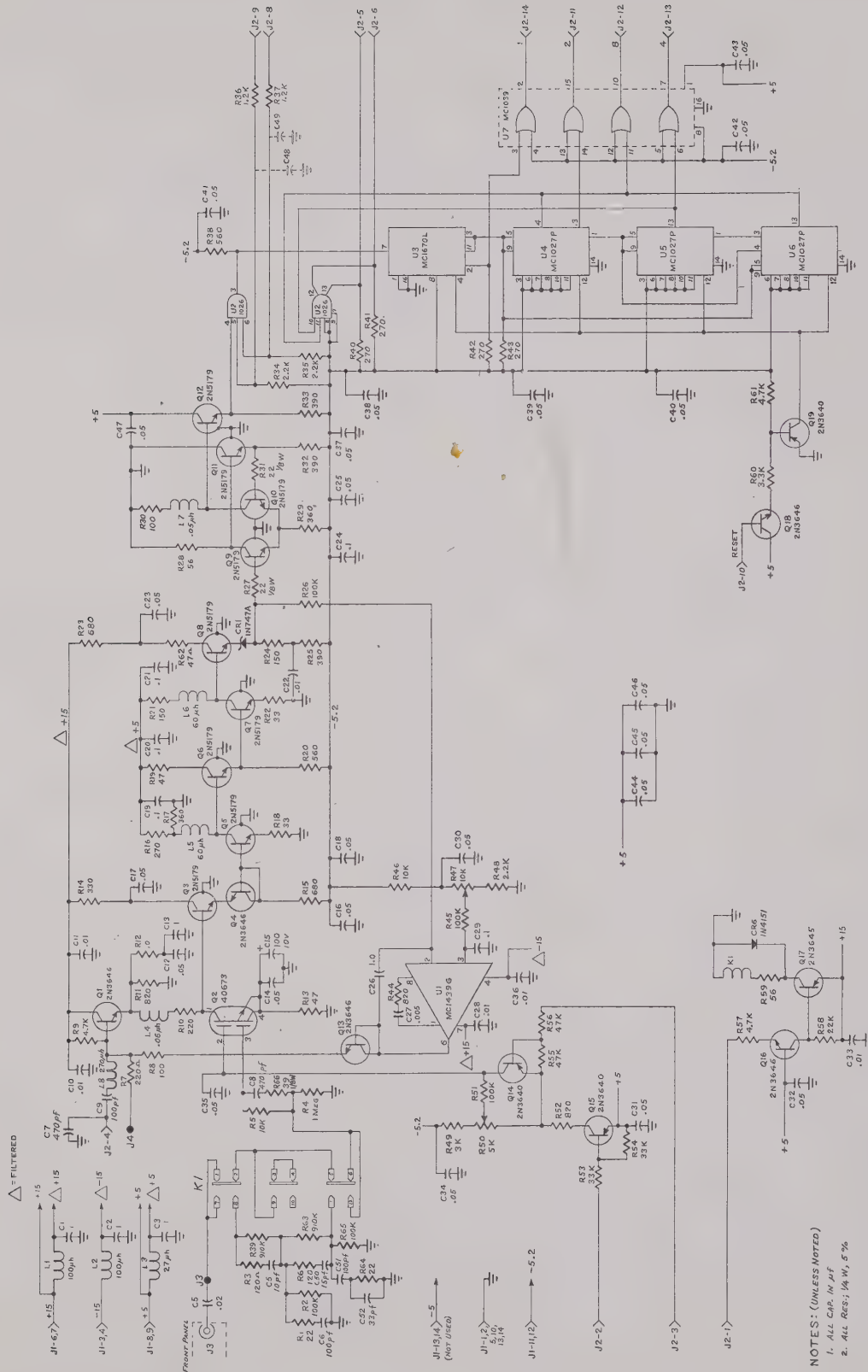

NOTES: (UNLESS NOTED)  
 1. ALL CAP. IN P.F.  
 2. ALL RES. 1/4 W, 5%

A4, 200MHZ AMP & DECADE SCHEMATIC, D39095R4

A4 200MHz AMP & DECADE PARTS LIST

REF.	DESCRIPTION	SD PART NO.
	200MHz Amp & Decade P.C. Assembly	D39098R5
	200MHz Amp & Decade Schematic	D39095R4
C1	Capacitor, 1 $\mu$ F, 25V, Disc	C0879
C2	Capacitor, 1 $\mu$ F, 25V, Disc	C0879
C3	Capacitor, 1 $\mu$ F, 25V, Disc	C0879
C4	Capacitor, .01 $\mu$ F, 100V, Disc	C0556
C5	Capacitor, 10pF, 500V, DM	C0527
C6	Capacitor, 100pF, 500V, DM	C0536
C7	Capacitor, 470pF, 300V, DM	C0542
C8	Capacitor, 470pF, 300V, DM	C0542
C9	Capacitor, 100pF, 500V, DM	C0536
C10	Capacitor, .01 $\mu$ F, 100V, Disc	C0556
C11	Capacitor, .01 $\mu$ F, 100V, Disc	C0556
C12	Capacitor, .05 $\mu$ F, 12V Disc	C0672
C13	Capacitor, 1 $\mu$ F, 25V, Disc	C0879
C14	Capacitor, .05 $\mu$ F, 12V, Disc	C0672
C15	Capacitor, 100 $\mu$ F, 10V, Disc	C0660
C16	Capacitor, .05 $\mu$ F, 12V, Disc	C0672
C17	Capacitor, .05 $\mu$ F, 12V, Disc	C0672
C18	Capacitor, .05 $\mu$ F, 12V, Disc	C0672
C19	Capacitor, .1 $\mu$ F, 10V, Disc	C0661
C20	Capacitor, .1 $\mu$ F, 10V, Disc	C0661
C21	Capacitor, .1 $\mu$ F, 10V, Disc	C0661
C22	Capacitor, .01 $\mu$ F, 100V, Disc	C0556
C23	Capacitor, .05 $\mu$ F, 12V, Disc	C0672
C24	Capacitor, .1 $\mu$ F, 10V, Disc	C0661
C25	Capacitor, .05 $\mu$ F, 12V, Disc	C0672
C26	Capacitor, 1 $\mu$ F, 25V, Disc	C0879
C27	Capacitor, .005 $\mu$ F, 150V, Disc	C0325
C28	Capacitor, .01 $\mu$ F, 100V, Disc	C0556
C29	Capacitor, 1 $\mu$ F, 10V, Disc	C0661
C30	Capacitor, .05 $\mu$ F, 12V, Disc	C0672
C31	Capacitor, .05 $\mu$ F, 12V, Disc	C0672
C32	Capacitor, .05 $\mu$ F, 12V, Disc	C0672
C33	Capacitor, .01 $\mu$ F, 100V, Disc	C0556
C34	Capacitor, .05 $\mu$ F, 12V, Disc	C0672
C35	Capacitor, .05 $\mu$ F, 12V, Disc	C0672

A4 200MHz AMP & DECADE PARTS LIST (Cont'd)

REF.	DESCRIPTION	SD PART NO.
C36	Capacitor, .01 $\mu$ F, 100V, Disc	C0556
C37	Capacitor, .05 $\mu$ F, 12V, Disc	C0672
C38	Capacitor, .05 $\mu$ F, 12V, Disc	C0672
C39	Capacitor, .05 $\mu$ F, 12V, Disc	C0672
C40	Capacitor, .05 $\mu$ F, 12V, Disc	C0672
C41	Capacitor, .05 $\mu$ F, 12V, Disc	C0672
C42	Capacitor, .05 $\mu$ F, 12V, Disc	C0672
C43	Capacitor, .05 $\mu$ F, 12V, Disc	C0672
C44	Capacitor, .05 $\mu$ F, 12V, Disc	C0672
C45	Capacitor, .05 $\mu$ F, 12V, Disc	C0672
C46	Capacitor, .05 $\mu$ F, 12V, Disc	C0672
C47	Capacitor, .05 $\mu$ F, 12V, Disc	C0672
C48	Capacitor, Selected	Cxxxx
C49	Capacitor, Selected	Cxxxx
CR1	Diode, 1N747A	CR5005
CR2	Not Used	
CR3	Not Used	
CR4	Not Used	
CR5	Not Used	
CR6	Diode, 1N4151	CR0150
J1	Integrated Circuit Socket, 14 Pin	X0186
J2	Integrated Circuit Socket, 14 Pin	X0186
J3	Connector, Post, AMP 61067-1	E0318
J4	Connector, Post, AMP 61067-1	E0318
K1	Relay, Printact #12BP3G	Kxxxx
L1	Inductor, 100 $\mu$ H	L0073
L2	Inductor, 100 $\mu$ H	L0073
L3	Inductor, 27 $\mu$ H	L0076
L4	Inductor, .06 $\mu$ H	L0158
L5	Inductor, .06 $\mu$ H	L0158
L6	Inductor, .06 $\mu$ H	L0158
L7	Inductor, .06 $\mu$ H	L0158
Q1	Transistor, 2N3646	Q0218
Q2	Transistor, 40673	Q0297
Q3	Transistor, 2N5179	Q0269
Q4	Transistor, 2N3646	Q0218
Q5	Transistor, 2N5179	Q0269

A4 200MHz AMP & DECADE PARTS LIST (Cont'd)

REF.	DESCRIPTION	SD PART NO.
Q6	Transistor, 2N5179	Q0269
Q7	Transistor, 2N5179	Q0269
Q8	Transistor, 2N5179	Q0269
Q9	Transistor, 2N5179	Q0269
Q10	Transistor, 2N5179	Q0269
Q11	Transistor, 2N5179	Q0269
Q12	Transistor, 2N5179	Q0269
Q13	Transistor, 2N3646	Q0218
Q14	Transistor, 2N3640	Q0178
Q15	Transistor, 2N3640	Q0178
Q16	Transistor, 2N3646	Q0218
Q17	Transistor, 2N3645	Q0215
Q18	Transistor, 2N3646	Q0218
R1	Resistor, 22 $\Omega$ , 1/4W, 5%	R1436
R2	Resistor, 100K, 1/4W, 5%	R0741
R3	Resistor, 120 $\Omega$ , 1/4W, 5%	R1461
R4	Resistor, 1M $\Omega$ , 1/4W, 5%	R0692
R5	Resistor, 10K, 1/4W, 5%	R0766
R6	Resistor, 120 $\Omega$ , 1/4W, 5%	R1461
R7	Resistor, 220 $\Omega$ , 1/4W, 5%	R0760
R8	Resistor, 100 $\Omega$ , 1/4W, 5%	R0966
R9	Resistor, 4.7K, 1/4W, 5%	R0892
R10	Resistor, 220 $\Omega$ , 1/4W, 5%	R0760
R11	Resistor, 820 $\Omega$ , 1/4W, 5%	R0762
R12	Resistor, 10 $\Omega$ , 1/4W, 5%	R0739
R13	Resistor, 47 $\Omega$ , 1/4W, 5%	R0743
R14	Resistor, 330 $\Omega$ , 1/4W, 5%	R0662
R15	Resistor, 680 $\Omega$ , 1/4W, 5%	R1234
R16	Resistor, 270 $\Omega$ , 1/4W, 5%	R0694
R17	Resistor, 360 $\Omega$ , 1/4W, 5%	R1571
R18	Resistor, 33 $\Omega$ , 1/4W, 5%	R1550
R19	Resistor, 47 $\Omega$ , 1/4W, 5%	R0743
R20	Resistor, 560 $\Omega$ , 1/4W, 5%	R0819
R21	Resistor, 150 $\Omega$ , 1/4W, 5%	R0983
R22	Resistor, 33 $\Omega$ , 1/4W, 5%	R1550
R23	Resistor, 680 $\Omega$ , 1/4W, 5%	R1234
R24	Resistor, 150 $\Omega$ , 1/4W, 5%	R0983
R25	Resistor, 390 $\Omega$ , 1/4W, 5%	R0880



## A4 200MHZ AMP &amp; DECADE PARTS LIST (Cont'd)

REF.	DESCRIPTION	SD PART NO.
R26	Resistor, 100K, 1/4W, 5%	R0741
R27	Resistor, 22 $\Omega$ , 1/8W, 5%	R1448
R28	Resistor, 56 $\Omega$ , 1/4W, 5%	R1554
R29	Resistor, 360 $\Omega$ , 1/4W, 5%	R1571
R30	Resistor, 100 $\Omega$ , 1/4W, 5%	R0966
R31	Resistor, 22 $\Omega$ , 1/8W, 5%	R1448
R32	Resistor, 390 $\Omega$ , 1/4W, 5%	R0880
R33	Resistor, 390 $\Omega$ , 1/4W, 5%	R0880
R34	Resistor, 2.2K, 1/4W, 5%	R0794
R35	Resistor, 2.2K, 1/4W, 5%	R0794
R36	Resistor, 1.2K, 1/4W, 5%	R0809
R37	Resistor, 1.2K, 1/4W, 5%	R0809
R38	Resistor, 560 $\Omega$ , 1/4W, 5%	R0819
R39	Resistor, 910K, 1/4W, 5%	R2312
R40	Resistor, 270 $\Omega$ , 1/4W, 5%	R0694
R41	Resistor, 270 $\Omega$ , 1/4W, 5%	R0694
R42	Resistor, 270 $\Omega$ , 1/4W, 5%	R0694
R43	Resistor, 270 $\Omega$ , 1/4W, 5%	R0694
R44	Resistor, 820 $\Omega$ , 1/4W, 5%	R0762
R45	Resistor, 100K, 1/4W, 5%	R0741
R46	Resistor, 10K, 1/4W, 5%	R0766
R47	Resistor, 10K, Potentiometer, CTS 340	R2383
R48	Resistor, 2.2K, 1/4W, 5%	R0794
R49	Resistor, 3K, 1/4W, 5%	R0711
R50	Resistor, 5K, Potentiometer, CTS 340	R2187
R51	Resistor, 100K, 1/4W, 5%	R0741
R52	Resistor, 820 $\Omega$ , 1/4W, 5%	R0762
R53	Resistor, 33K, 1/4W, 5%	R0780
R54	Resistor, 33K, 1/4W, 5%	R0780
R55	Resistor, 47K, 1/4W, 5%	R0777
R56	Resistor, 47K, 1/4W, 5%	R0777
R57	Resistor, 4.7K, 1/4W, 5%	R0892
R58	Resistor, 22K, 1/4W, 5%	R0768
R59	Resistor, 56 $\Omega$ , 1/4W, 5%	R1554
R60	Resistor, 3.3K, 1/4W, 5%	R0742
R61	Resistor, 4.7K, 1/4W, 5%	R0892
R62	Resistor, 47 $\Omega$ , 1/4W, 5%	R0743
U1	Integrated Circuit, MC1439G	25729
U2	Integrated Circuit, MC1026	

A4 200MHz AMP & DECADE PARTS LIST (Cont'd)

REF	DESCRIPTION	SD PART NO.
U3	Integrated Circuit, MC1670L	25765
U4	Integrated Circuit, MC1027P	25719
U5	Integrated Circuit, MC1027P	25719
U6	Integrated Circuit, MC1027P	25719
U7	Integrated Circuit, MC1039	
C50	Capacitor, 15pF, 500V, DM	C0528
C51	Capacitor, 100pF, 500V, DM	C0536
C52	Capacitor, 33pF, 500V	C0877
Q19	Transistor, 2N3640	Q0178
R63	Resistor, 910K, 1/4W, 5%	R2312
R64	Resistor, 22 $\Omega$ , 1/4W, 5%	R1436
R65	Resistor, 100K, 1/4W, 5%	R0741
R66	Resistor, 39 $\Omega$ , 1/8W, 5%	R1829
XQ1	Not Used	
XQ2	Transistor Pad	H1838
XQ3	Transistor Pad	H1838
XQ4	Not Used	
XQ5	Transistor Pad	H1838
XQ6	Transistor Pad	H1838
XQ7	Transistor Pad	H1838
XQ8	Transistor Pad	H1838
XQ9	Transistor Pad	H1838
XQ10	Transistor Pad	H1838
XQ11	Transistor Pad	H1838
XQ12	Transistor Pad	H1838
XQ13	Not Used	
XQ14	Not Used	
XQ15	Not Used	
XQ16	Not Used	
XQ17	Transistor Pad	H0515

NOTES

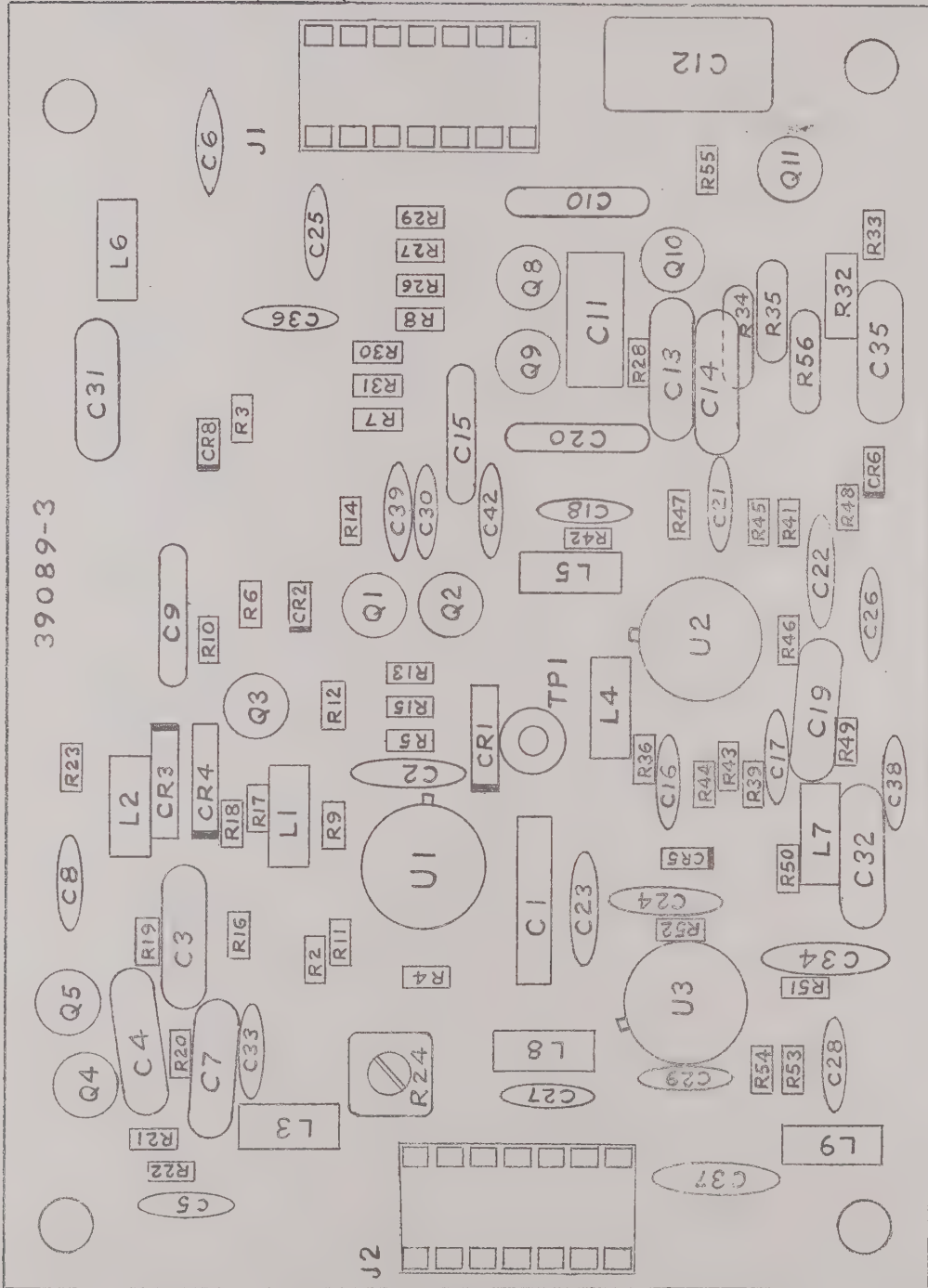

A5, ACTO P.C. ASSEMBLY, C39090R2

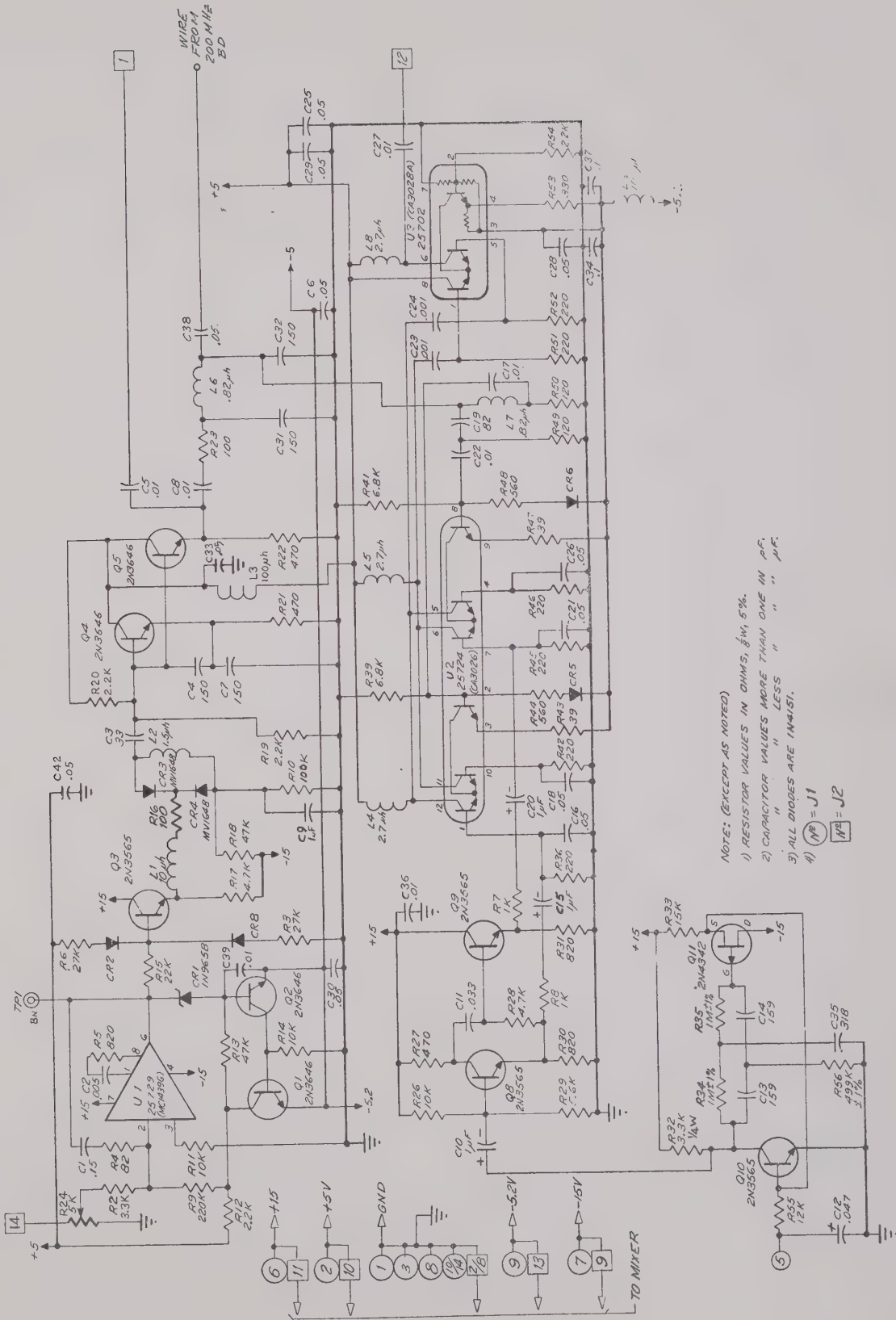

NOTE: (EXCEPT AS NOTED)

- 1) RESISTOR VALUES IN OHMS,  $\frac{1}{4}$ W, 5%.
- 2) CAPACITOR VALUES MORE THAN ONE IN P.F.
- 3) ALL DIODES ARE 1N4151.
- 4)  $\square$  = J1     $\square$  = J2

## A5 ACTO PARTS LIST

REF.	DESCRIPTION	SD PART NO.
	A5 ACTO P.C. Assembly	C39090
	A5 ACTO Schematic	C39087
C1	Capacitor, .15 $\mu$ F, 100V	C0237
C2	Capacitor, .005 $\mu$ F, 150V	C0325
C3	Capacitor, 33pF	C0531
C4	Capacitor, 150pF	C0537
C5	Capacitor, .01 $\mu$ F, 100V	C0556
C6	Capacitor, .05 $\mu$ F, 12V	C0672
C7	Capacitor, 150pF	C0537
C8	Capacitor, .01 $\mu$ F, 100V	C0556
C9	Capacitor, 1 $\mu$ F, 25V	C0879
C10	Capacitor, 1 $\mu$ F, 25V	C0879
C11	Capacitor, .033 $\mu$ F	C0735
C12	Capacitor, .047 $\mu$ F, Tant	C0700
C13	Capacitor, 159pF, 1%	C1146
C14	Capacitor, 159pF, 1%	C1146
C15	Capacitor, 1 $\mu$ F, 25V	C0879
C16	Capacitor, .05 $\mu$ F, 12V	C0672
C17	Capacitor, .01 $\mu$ F, 100V	C0556
C18	Capacitor, .05 $\mu$ F, 12V	C0672
C19	Capacitor, 82pF	C0535
C20	Capacitor, 1 $\mu$ F, 25V	C0879
C21	Capacitor, .05 $\mu$ F, 12V	C0672
C22	Capacitor, .01 $\mu$ F, 100V	C0556
C23	Capacitor, .001 $\mu$ F, 1KV	C0235
C24	Capacitor, .001 $\mu$ F, 1KV	C0235
C25	Capacitor, .05 $\mu$ F, 12V	C0672
C26	Capacitor, .05 $\mu$ F, 12V	C0672
C27	Capacitor, .01 $\mu$ F, 100V	C0556
C28	Capacitor, .05 $\mu$ F, 12V	C0672
C29	Capacitor, .05 $\mu$ F, 12V	C0672
C30	Capacitor, .05 $\mu$ F, 12V	C0672
C31	Capacitor, 150pF	C0537
C32	Capacitor, 150pF	C0537
C33	Capacitor, .05 $\mu$ F, 12V	C0672
C34	Capacitor, .1 $\mu$ F	C0661
C35	Capacitor, 318pF, 1%	C1145

## A5 ACTO PARTS LIST (Cont'd)

REF	DESCRIPTION	SD PART NO
C36	Capacitor, .01 $\mu$ F, 100V	C0556
C37	Capacitor, .1 $\mu$ F	C0661
C38	Capacitor, .05 $\mu$ F, 12V	C0672
C39	Capacitor, .01 $\mu$ F, 100V	C0556
C40	Not Used	
C41	Not Used	
C42	Capacitor, .05 $\mu$ F, 12V	C0672
CR1	Diode, 1N965B	CR0139
CR2	Diode, 1N4151	CR0150
CR3	Diode, MV1648	CR0359
CR4	Diode, MV1648	CR0359
CR5	Diode, 1N4151	CR0150
CR6	Diode, 1N4151	CR0150
CR7	Not Used	
CR8	Diode, 1N4151	CR0150
J1	Integrated Circuit Socket, 7 Term	X0184
J2	Integrated Circuit Socket, 7 Term	X0184
L1	Inductor, 10 $\mu$ H	L0153
L2	Inductor, 1.5 $\mu$ H	L0164
L3	Inductor, 100 $\mu$ H	L0156
L4	Inductor, 2.7 $\mu$ H	L0165
L5	Inductor, 2.7 $\mu$ H	L0165
L6	Inductor, .82 $\mu$ H	L0163
L7	Inductor, .82 $\mu$ H	L0163
L8	Inductor, 2.7 $\mu$ H	L0165
L9	Inductor, 100 $\mu$ H	L0156
Q1	Transistor, 2N3646	Q0218
Q2	Transistor, 2N3646	Q0218
Q3	Transistor, 2N3565	Q0237
Q4	Transistor, 2N3646	Q0218
Q5	Transistor, 2N3646	Q0218
Q6	Not Used	
Q7	Not Used	
Q8	Transistor, 2N3565	Q0237
Q9	Transistor, 2N3565	Q0237
Q10	Transistor, 2N3565	Q0237
Q11	Transistor, 2N4342	Q0243

A5 ACTO PARTS LIST (Cont'd)

REF.	DESCRIPTION	SD PART NO.
R1	Not Used	
R2	Resistor, 3.3K, 1/8W, 5%	R1456
R3	Resistor, 27K, 1/8W, 5%	R2432
R4	Resistor, 82Ω, 1/8W, 5%	R1745
R5	Resistor, 820Ω, 1/8W, 5%	R2462
R6	Resistor, 27K, 1/8W, 5%	R2432
R7	Resistor, 1K, 1/8W, 5%	R1453
R8	Resistor, 1K, 1/8W, 5%	R1453
R9	Resistor, 220K, 1/8W, 5%	R2567
R10	Resistor, 100K, 1/8W, 5%	R2465
R11	Resistor, 10K, 1/8W, 5%	R1437
R12	Resistor, 2.2K, 1/8W, 5%	R1476
R13	Resistor, 47K, 1/8W, 5%	R1433
R14	Resistor, 10K, 1/8W, 5%	R1437
R15	Resistor, 22K, 1/8W, 5%	R1742
R16	Resistor, 100Ω, 1/8W, 5%	R1441
R17	Resistor, 4.7K, 1/8W, 5%	R1733
R18	Resistor, 47K, 1/8W, 5%	R1433
R19	Resistor, 2.2K, 1/8W, 5%	R1476
R20	Resistor, 2.2K, 1.8W, 5%	R1476
R21	Resistor, 470Ω, 1/8W, 5%	R1451
R22	Resistor, 470Ω, 1/8W, 5%	R1451
R23	Resistor, 100Ω, 1/8W, 5%	R1441
R24	Resistor, VAR., 5K, 2W, 30%	R2187
R25	Not Used	
R26	Resistor, 10K, 1/8W, 5%	R1437
R27	Resistor, 470Ω, 1/8W, 5%	R1451
R28	Resistor, 4.7K, 1/8W, 5%	R1733
R29	Resistor, 5.6K, 1/8W, 5%	R1458
R30	Resistor, 820Ω, 1/8W, 5%	R2462
R31	Resistor, 820Ω, 1/8W, 5%	R2462
R32	Resistor, 3.3K, 1/4W, 5%	R0742
R33	Resistor, 15K, 1/8W, 5%	R1438
R34	Resistor, 1MΩ, 1/8W, 5%	R2371
R35	Resistor, 1MΩ, 1/8W, 5%	R2371
R36	Resistor, 220Ω, 1/8W, 5%	R1743
R37	Not Used	
R38	Not Used	
R39	Resistor, 6.8K, 1/8W, 5%	R1459
R40	Not Used	



A5 ACTO PARTS LIST (Cont'd)

REF.	DESCRIPTION	SD PART NO.
R41	Resistor, 6.8K, 1/8W, 5%	R1459
R42	Resistor, 220Ω, 1/8W, 5%	R1743
R43	Resistor, 39Ω, 1/8W, 5%	R1829
R44	Resistor, 560Ω, 1/8W, 5%	R1452
R45	Resistor, 220Ω, 1/8W, 5%	R1743
R46	Resistor, 220Ω, 1/8W, 5%	R1743
R47	Resistor, 39Ω, 1/8W, 5%	R1829
R48	Resistor, 560Ω, 1/8W, 5%	R1452
R49	Resistor, 120Ω, 1/8W, 5%	R2459
R50	Resistor, 120Ω, 1/8W, 5%	R2459
R51	Resistor, 220Ω, 1/8W, 5%	R1743
R52	Resistor, 220Ω, 1/8W, 5%	R1743
R53	Resistor, 330Ω, 1/8W, 5%	R1444
R54	Resistor, 2.2K, 1/8W, 5%	R1476
R55	Resistor, 12K, 1/8W, 5%	R2464
R56	Resistor, 499K, 1/8W, 1%	R2372
U1	Integrated Circuit, MC1439G	25729
U2	Integrated Circuit, CA3026	25724
U3	Integrated Circuit, CA3028A	25702

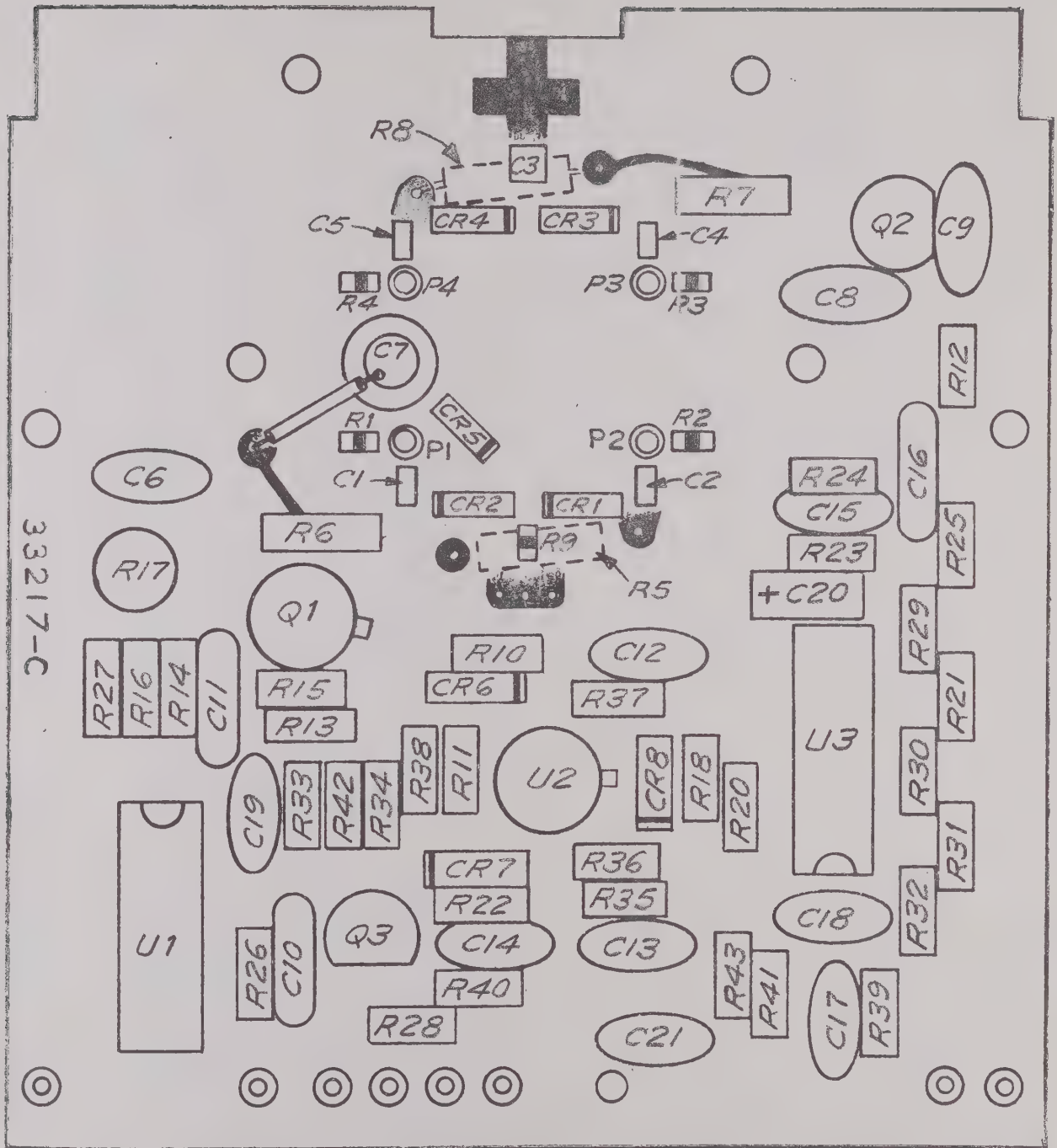

A6, MIXER P.C. ASSEMBLY, C33218C

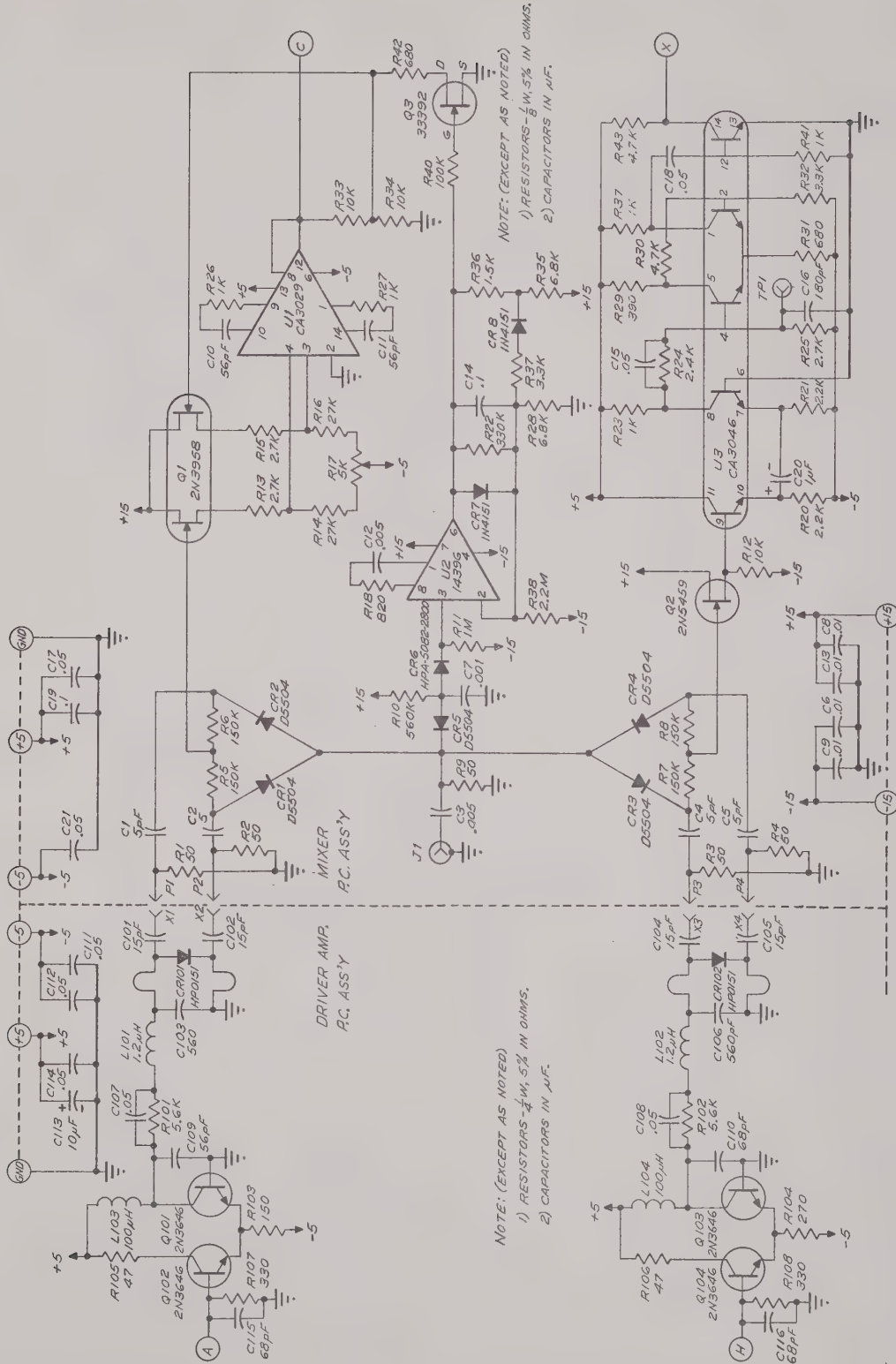

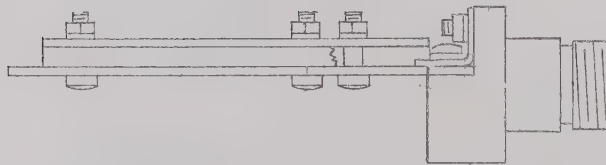
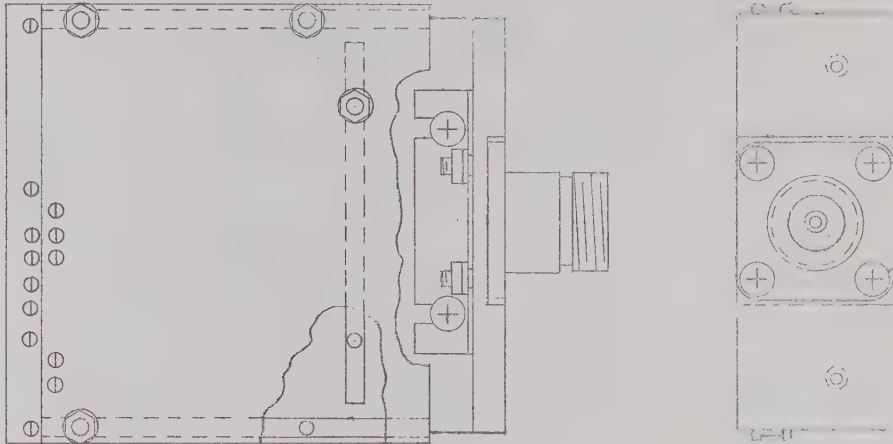

A6, MIXER FINAL ASSEMBLY, C33351B

A6 MIXER PARTS LIST

REF.	DESCRIPTION	SD PART NO.
	Mixer P.C. Assembly	C33218C
	Mixer Schematic	C27988C
C1	Capacitor, 5pF, Chip	C1187
C2	Capacitor, 5pF, Chip	C1187
C3	Capacitor, .005 $\mu$ F, Chip	C1245
C4	Capacitor, 5pF, Chip	C1187
C5	Capacitor, 5pF, Chip	C1187
C6	Capacitor, .01 $\mu$ F, 100V, Disc	C0556
C7	Capacitor, .001 $\mu$ F, Disc (Chip)	03287080
C8	Capacitor, .01 $\mu$ F, 100V, Disc	C0556
C9	Capacitor, .01 $\mu$ F, 100V, Disc	C0556
C10	Capacitor, 56pF, 500V, DM	C0882
C11	Capacitor, 56pF, 500V, DM	C0882
C12	Capacitor, .005 $\mu$ F, 150V, Disc	C0325
C13	Capacitor, .01 $\mu$ F, 100V, Disc	C0556
C14	Capacitor, .1 $\mu$ F, 10V, Disc	C0661
C15	Capacitor, .05 $\mu$ F, 12V, Disc	C0672
C16	Capacitor, 180pF, 500V, DM	C1138
C17	Capacitor, .05 $\mu$ F, 12V, Disc	C0672
C18	Capacitor, .05 $\mu$ F, 12V, Disc	C0672
C19	Capacitor, .1 $\mu$ F, 10V, Disc	C0661
C20	Capacitor, 1 $\mu$ F, 35V, Tant	C0524
C21	Capacitor, .05 $\mu$ F, 12V, Disc	C0672
CR1	Diode, D5504	CR0358
CR2	Diode, D5504	CR0358
CR3	Diode, D5504	CR0358
CR4	Diode, D5504	CR0358
CR5	Diode, D5504	CR0358
CR6	Diode, HPA 5082-2800	CR0363
CR7	Diode, 1N4151	CR0150
CR8	Diode, 1N4151	CR0150
Q1	Transistor, 2N3958	26015100
Q2	Transistor, 2N5459	Q0264
Q3	Transistor, SD Spec 33392	33392
R1	Resistor, 50 $\Omega$ , Chip	R2494
R2	Resistor, 50 $\Omega$ , Chip	R2494
R3	Resistor, 50 $\Omega$ , Chip	R2494
R4	Resistor, 50 $\Omega$ , Chip	R2494
R5	Resistor, 150K, 1/4W, 1%, MF	R2421

## A6 MIXER PARTS LIST (Cont'd)

REF.	DESCRIPTION	SD PART NO.
R6	Resistor, 150K, 1/4, 1%, MF	R2421
R7	Resistor, 150K, 1/4, 1%, MF	R2421
R8	Resistor, 150K, 1/4, 1%, MF	R2421
R9	Resistor, 50, Chip	R2494
R10	Resistor, 560K, 1/8W, 5%	R2536
R11	Resistor, 1M, 1/8W, 5%	R1435
R12	Resistor, 10K, 1/8W, 5%	R1437
R13	Resistor, 2.7K, 1/8W, 5%	R1749
R14	Resistor, 27K, 1/8W, 5%	R2432
R15	Resistor, 2.7K, 1/8W, 5%	R1749
R16	Resistor, 27K, 1/8W, 5%	R2432
R17	Resistor, 5K, Potentiometer	R2187
R18	Resistor, 820 $\Omega$ , 1/8W, 5%	R2462
R19	Not Used	
R20	Resistor, 2.2K, 1/8W, 5%	R1476
R21	Resistor, 2.2K, 1/8W, 5%	R1476
R22	Resistor, 330K, 1/8W, 5%	R2535
R23	Resistor, 1K, 1/8W, 5%	R1453
R24	Resistor, 2.4K, 1/8W, 5%	R2358
R25	Resistor, 2.7K, 1/8W, 5%	R1749
R26	Resistor, 1K, 1/8W, 5%	R1453
R27	Resistor, 1K, 1/8W, 5%	R1453
R28	Resistor, 6.8K, 1/8W, 5%	R1459
R29	Resistor, 390 $\Omega$ , 1/8W, 5%	R1450
R30	Resistor, 4.7K, 1/8W, 5%	R1733
R31	Resistor, 680 $\Omega$ , 1/8W, 5%	R2461
R32	Resistor, 3.3K, 1/8W, 5%	R1456
R33	Resistor, 10K, 1/8W, 5%	R1437
R34	Resistor, 10K, 1/8W, 5%	R1437
R35	Resistor, 6.8K, 1/8W, 5%	R1459
R36	Resistor, 1.5K, 1/8W, 5%	R2463
R37	Resistor, 3.3K, 1/8W, 5%	R1456
R38	Resistor, 2.2M, 1/8W, 5%	R2635
R39	Resistor, 1K, 1/8W, 5%	R1453
R40	Resistor, 100K, 1/8W, 5%	R2465
R41	Resistor, 1K, 1/8W, 5%	R1453
R42	Resistor, 680 $\Omega$ , 1/8W, 5%	R2461
R43	Resistor, 4.7K, 1/8W, 5%	R1733
U1	Integrated Circuit, CA3029	25757
U2	Integrated Circuit, MC1439G	25729
U3	Integrated Circuit, CA3046	25725

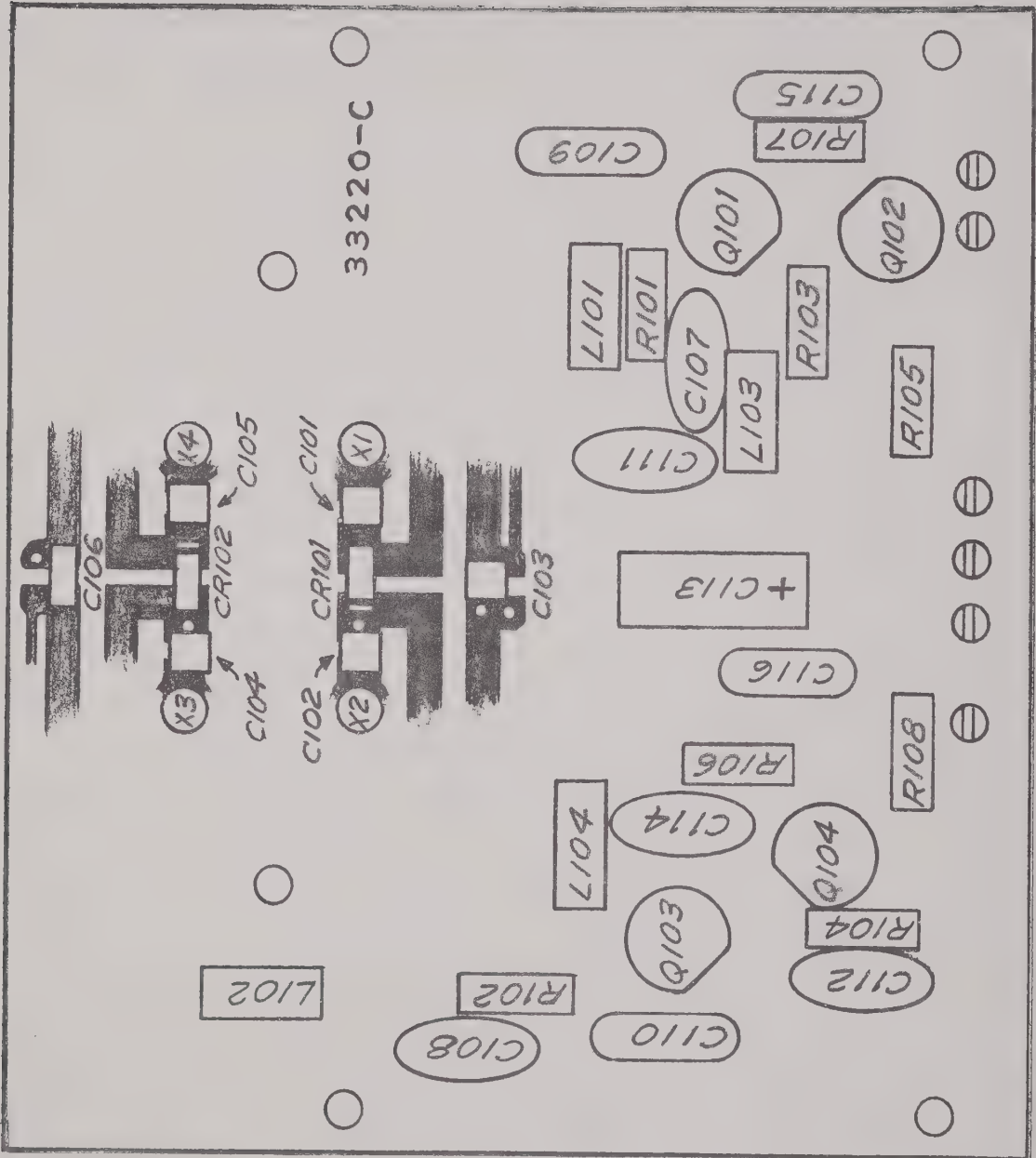

A6, DRIVER AMP P.C. ASSEMBLY, C33221C

# A6 DRIVER AMP PARTS LIST

REF.	DESCRIPTION	SD PART NO.
	A6 Driver Amp P.C. Assembly	C33221C
	A6 Driver Amp Schematic	C27988C
C101	Capacitor, 15pF, Chip	C1163
C102	Capacitor, 15pF, Chip	C1163
C103	Capacitor, 560pF, Chip	C1235
C104	Capacitor, 15pF, Chip	C1163
C105	Capacitor, 15pF, Chip	C1163
C106	Capacitor, 560pF, Chip	C1235
C107	Capacitor, .05 $\mu$ F, 12V	C0672
C108	Capacitor, .05 $\mu$ F, 12V	C0672
C109	Capacitor, 56pF, 500V	C0534
C110	Capacitor, 68pF, 500V	C0635
C111	Capacitor, .05 $\mu$ F, 12V	C0672
C112	Capacitor, .05 $\mu$ F, 12V	C0672
C113	Capacitor, 10 $\mu$ F, 20V	C0353
C114	Capacitor, .05 $\mu$ F, 12V	C0672
C115	Capacitor, 68pF, 500V	C0635
C116	Capacitor, 68pF, 500V	C0635
CR101	Diode, HP0151	CR0269
CR102	Diode, HP0151	CR0269
L101	Inductor, 1.2 $\mu$ H, 10%	
L102	Inductor, 1.2 $\mu$ H, 10%	
L103	Inductor, 100 $\mu$ H	L0073
L104	Inductor, 100 $\mu$ H	L0073
Q101	Transistor, 2N3646	Q0218
Q102	Transistor, 2N3646	Q0218
Q103	Transistor, 2N3646	Q0218
Q104	Transistor, 2N3646	Q0218
R101	Resistor, 5.6K, 1/4W, 5%	R0821
R102	Resistor, 5.6K, 1/4W, 5%	R0821
R103	Resistor, 150 $\Omega$ , 1/4W, 5%	R0983
R104	Resistor, 270 $\Omega$ , 1/4W, 5%	R0694
R105	Resistor, 47 $\Omega$ , 1/4W, 5%	R0743
R106	Resistor, 47 $\Omega$ , 1/4W, 5%	R0743
R107	Resistor, 330 $\Omega$ , 1/4W, 5%	R0662
R108	Resistor, 330 $\Omega$ , 1/4W, 5%	R0662



## CHAPTER 7 STANDARD OPTIONS

### 7.1 INTRODUCTION

The Standard Options available for the SD Model 6053/3 Frequency Counter are described in the following sections. These are extra cost items to tailor your unit for specific application. Non-standard Options may be requested and will be described in this chapter when applicable.

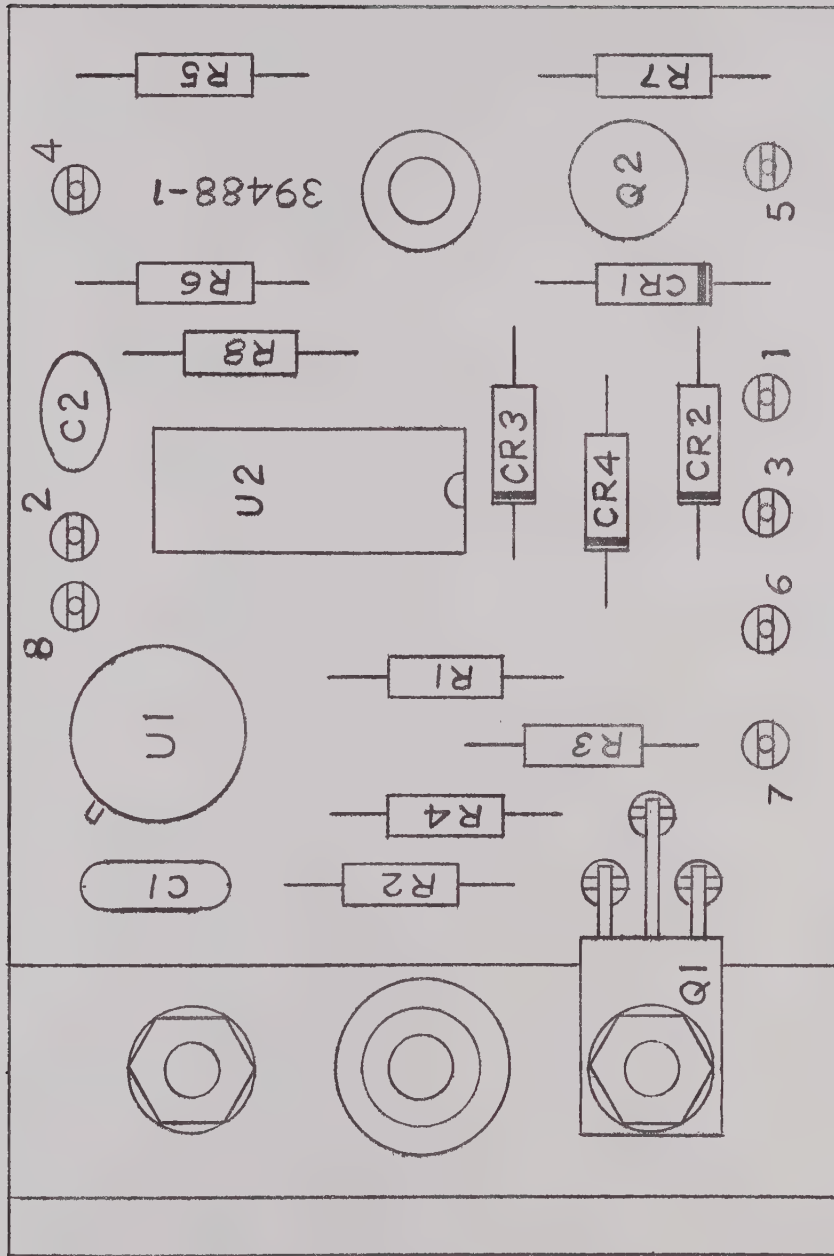

U1, 3MHZ OSCILLATOR ASSEMBLY, B39487R1

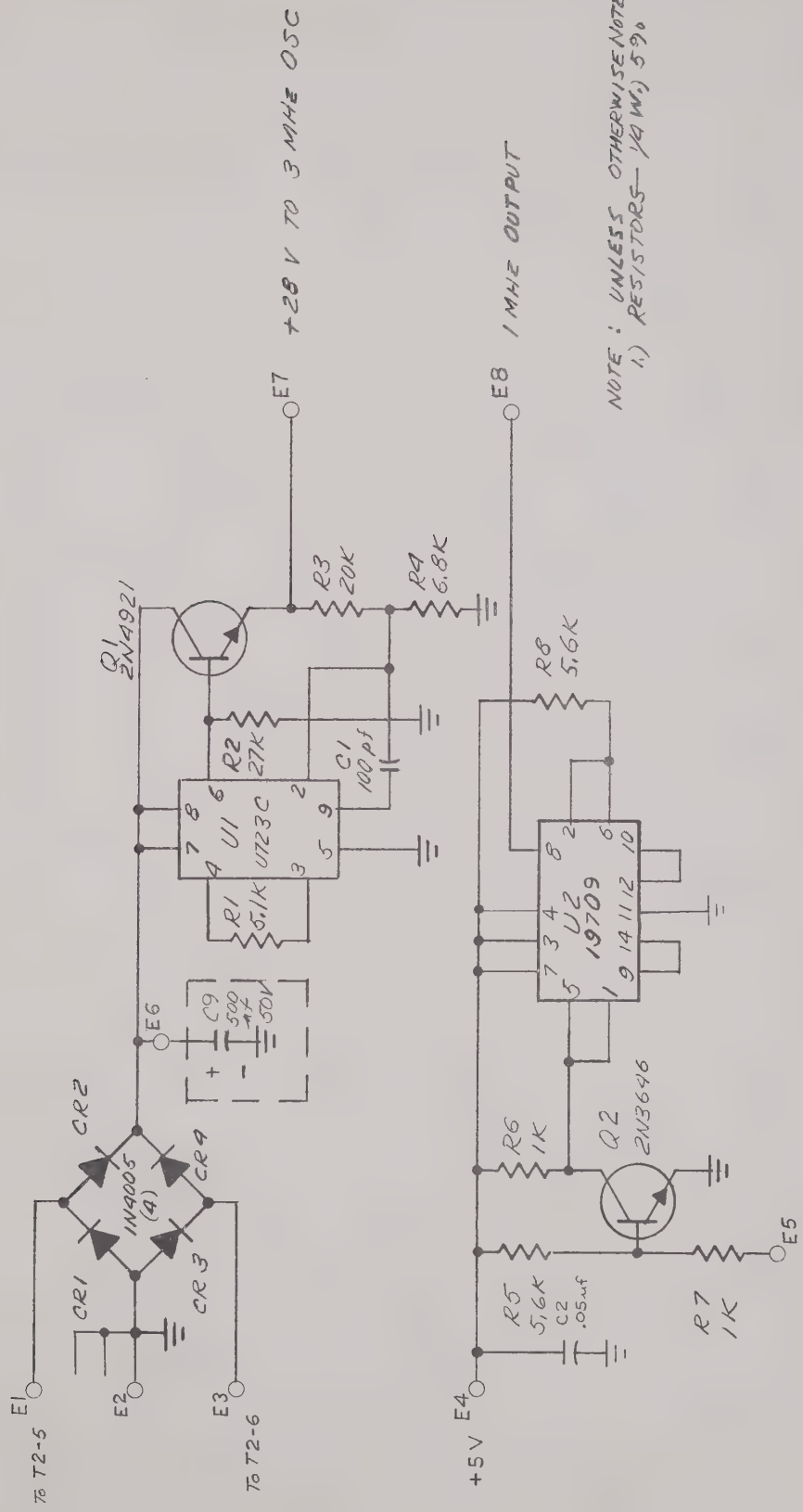

NOTE: UNLESS OTHERWISE NOTED  
 1) RESISTORS - 1/4 W, 5%  
 CAPS - 50V

FROM 3MHz OSC

U1, 3MHz OSCILLATOR SCHEMATIC, B39490R1

OSCILLATOR OPTION PARTS LIST

REF.	DESCRIPTION	SD PART NO.
	Oscillator P.C. Assembly	B39487R1
	Oscillator Schematic	B39490R1
C1	Capacitor, 100pF, 500V, 5%	C0536
C2	Capacitor, .05 $\mu$ F, 12V	C0672
CR1	Diode, 1N4005	CR0284
CR2	Diode, 1N4005	CR0284
CR3	Diode, 1N4005	CR0284
CR4	Diode, 1N4005	CR0284
Q1	Transistor, 2N4921	Q0267
Q2	Transistor, 2N3646	Q0218
R1	Resistor, 5.1K, 1/4W, 5%	R0693
R2	Resistor, 27K, 1/4W, 5%	R0824
R3	Resistor, 20K, 1/4W, 5%	R0964
R4	Resistor, 6.8K, 1/4W, 5%	R0696
R5	Resistor, 5.6K, 1/4W, 5%	R0821
R6	Resistor, 1K, 1/4W, 5%	R0765
R7	Resistor, 1K, 1/4W, 5%	R0765
R8	Resistor, 5.6K, 1/4W, 5%	R0821
U1	Integrated Circuit, U723C	25756
U2	Integrated Circuit, SN7473N	19709

D3 OPTION  
BCD PIN ASSIGNMENTS

DIGIT DISPLAYED	BCD	PIN	DIGIT DISPLAYED	BCD	PIN	
10 <sup>0</sup>	1	1	10 <sup>6</sup>	1	13	
	2	2		2	14	
	4	26		4	38	
	8	27		8	39	
10 <sup>1</sup>	1	3	10 <sup>7</sup>	1	15	
	2	4		2	16	
	4	28		4	40	
	8	29		8	41	
10 <sup>2</sup>	1	5	ANNUNCIATION			
	2	6				
	4	30		Measurement Unit	1	17
	8	31			2	18
10 <sup>3</sup>	1	7	Decimal Point	4	42	
	2	8		8	43	
	4	32		1	19	
	8	33		2	20	
10 <sup>4</sup>	1	9	RECORDER CONTROL	4	44	
	2	10		8	45	
	4	34				
	8	35				
10 <sup>5</sup>	1	11	+ Reference		25	
	2	12	- Reference		24	
	4	36	Instrument Ground		50	
	8	37	Print Command *		48	
			Inhibit Transfer		47	

\* Positive-going 15-volt pulse (0-volt reference) at end of count.

J4 (BCD OUT) Connector = Amphenol 57-40500  
Mating Connector = Amphenol 57-30500

GHz = BCD 7  
MHz = BCD 1

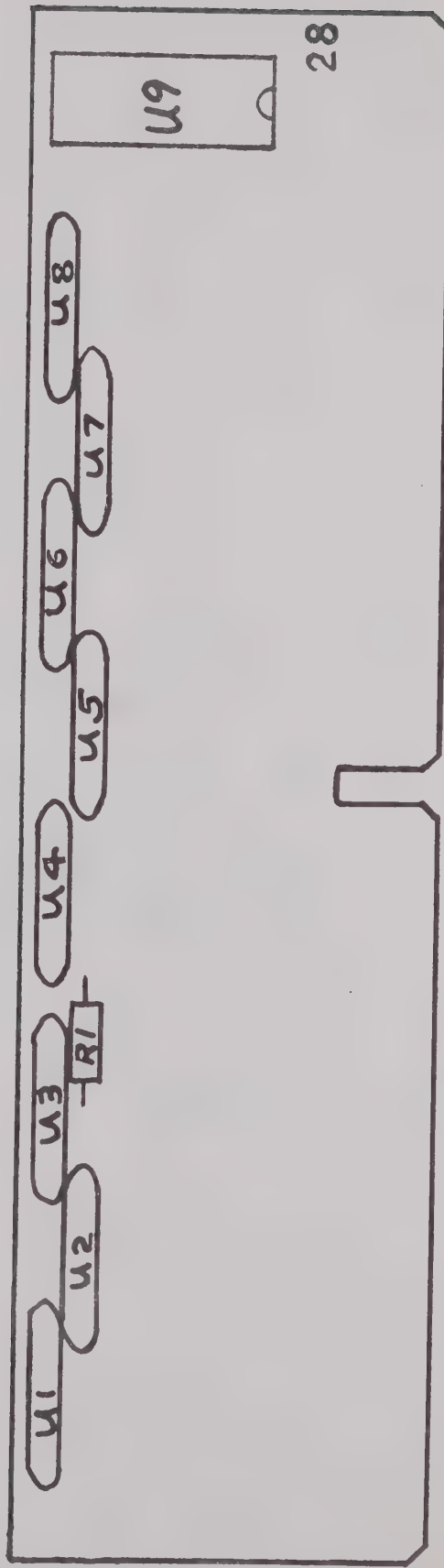

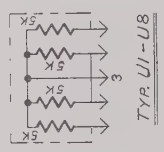
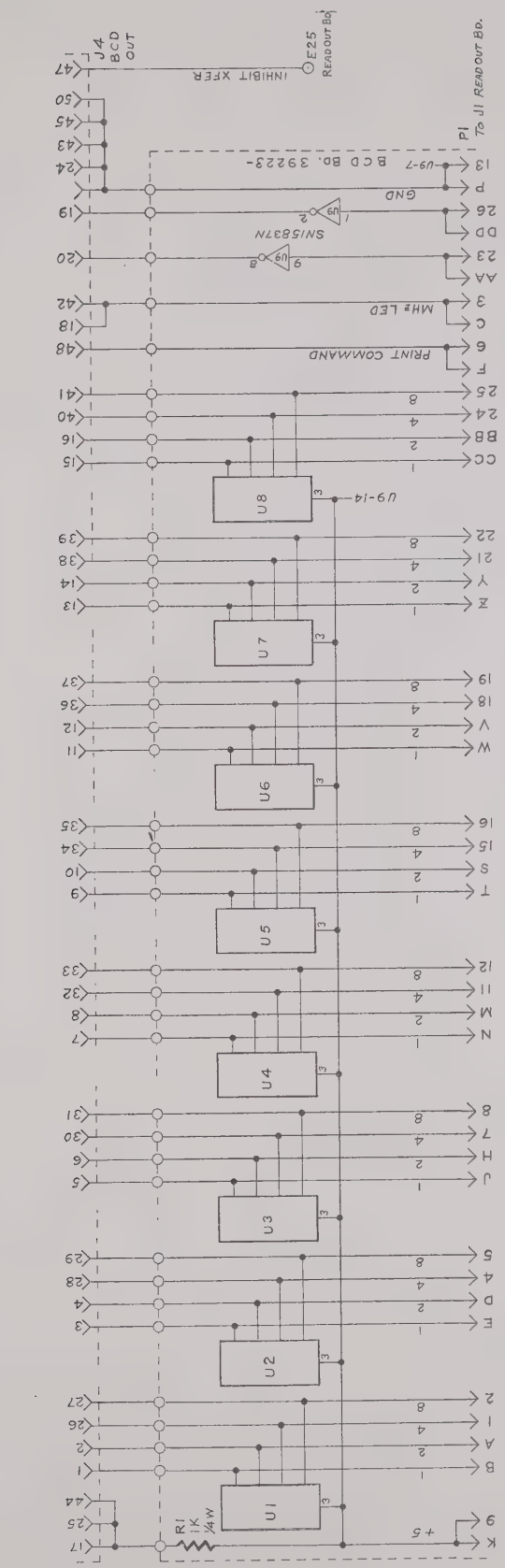

TYR. UI-U8

## BCD OPTION PARTS LIST

REF.	DESCRIPTION	SD PART NO.
	BCD Assembly	A39119
	BCD Schematic	C39113
R1	Resistor, 1K, 1/4W, 5%	R0765
U1	Resistor Assembly, (4) 5K	27867
U2	Resistor Assembly, (4) 5K	27867
U3	Resistor Assembly, (4) 5K	27867
U4	Resistor Assembly, (4) 5K	27867
U5	Resistor Assembly, (4) 5K	27867
U6	Resistor Assembly, (4) 5K	27867
U7	Resistor Assembly, (4) 5K	27867
U8	Resistor Assembly, (4) 5K	27867
U9	Integrated Circuit, SN15837N	25728



P OPTION  
REMOTE CONTROL PIN ASSIGNMENTS

PIN NO.	CONTROLS
1	Inhibit Reset
2	Reset (closure to ground will reset instrument only when gate is closed.)
4	FUNCTION "B"
5	FUNCTION "C"
6	FUNCTION "D"
8	RESOLUTION "B"
9	RESOLUTION "C"
10	RESOLUTION "D"
12	+5V
14	Ground

DESIRED FUNCTION	GROUND PINS	DESIRED RESOLUTION	GROUND PINS
ACTO	4 & 6	$10^{-1}$	NONE
TEST	6	1	8
X1	NONE	10	9
X10	4	$10^2$	8 & 9
X100	5	$10^3$	8 & 10
X1000	4 & 5	$10^4$	9 & 10
		$10^5$	8, 9, & 10

J5 (REMOTE CONTROL) = Amphenol 57-40140  
Mating Connector = Amphenol 57-30140





MP MASTER



MA34054